

CERTARO NS6/2000 sand and oil separator with TEGRA 600x1.5 M maintenance shaft
h = 1270 ... 3000 mm

(X)

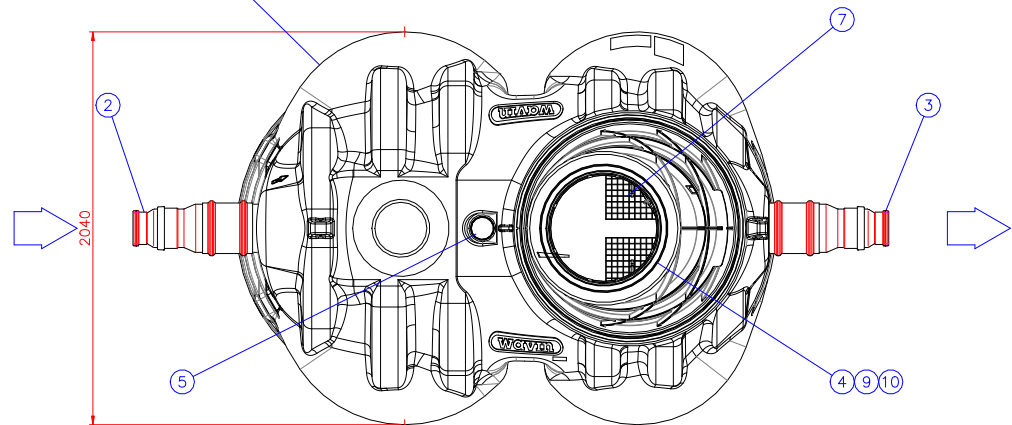
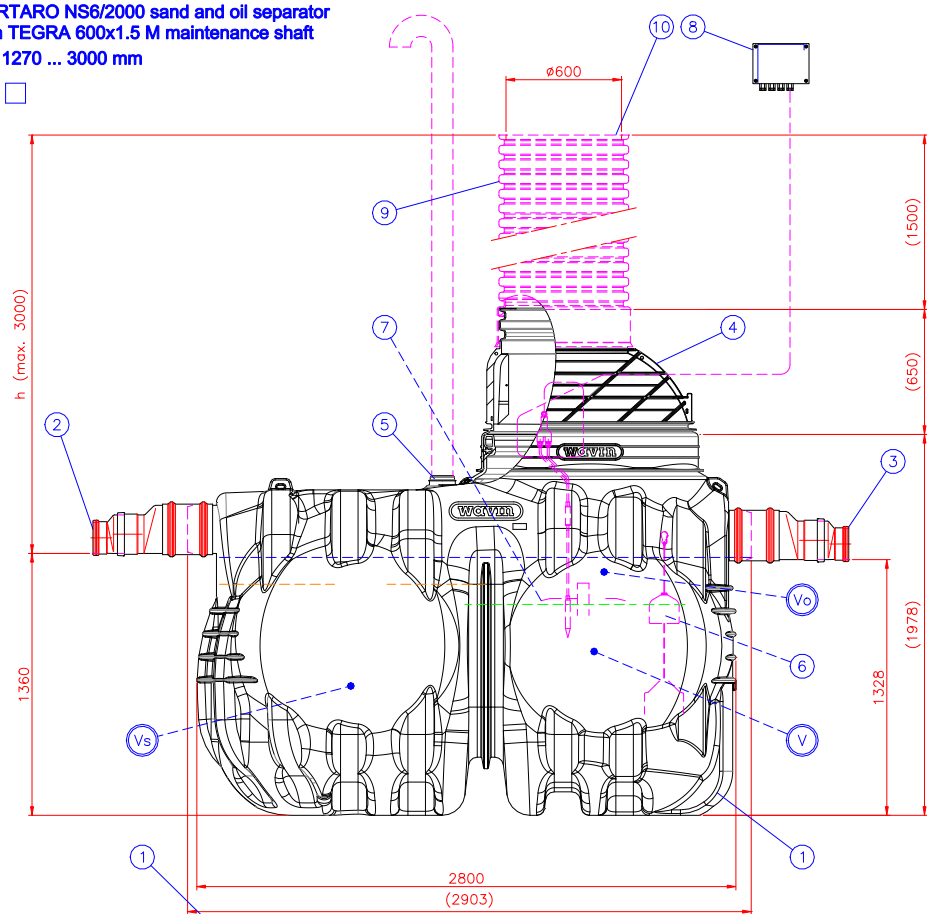

CERTARO NS6/2000 sand and oil separator without TEGRA 600x1.5 M maintenance shaft
h = 1270 mm

(X)

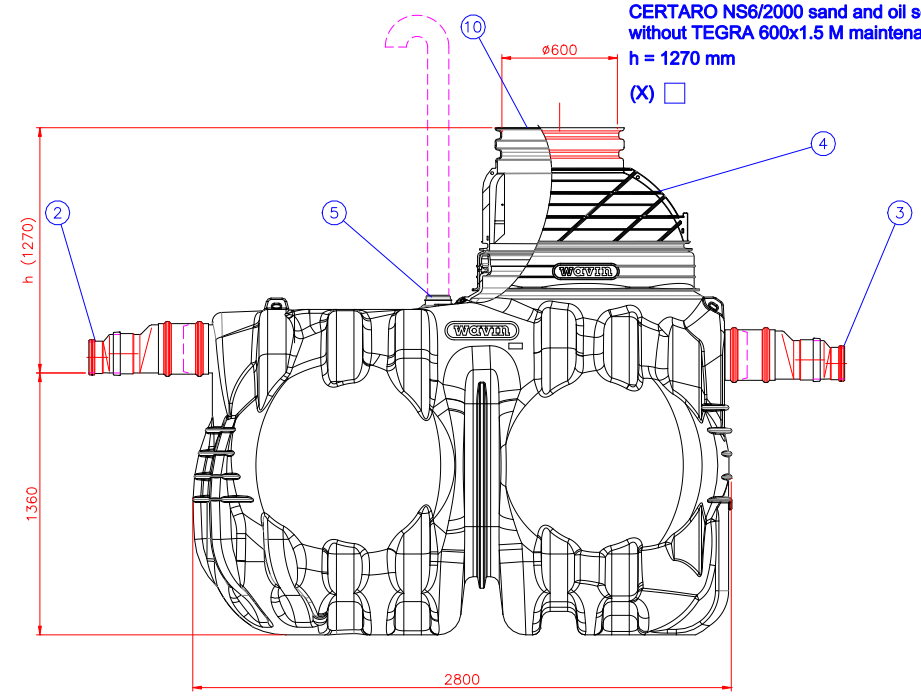

**Maximum SLW60 (100kN/m²) traffic load if 1,0m hard surface coverage above inlet (water level).
 Maximum groundwater level 2,5m above bottom of tank.
 Max depth is 3,0m from cover down to inlet (water level).**

h = Installation height from inlet to ground surface

h = _____ (max. 3000 mm)

Weight 350 kg

10	ACCESSORY: Cover (as needed)			(X) <input type="checkbox"/>
9	ACCESSORY: TEGRA 600 maintenance shaft with socket and 600 sealing ring			(X) <input type="checkbox"/>
8	Alarm system (central unit with oil surface and blockage detection probes)			
7	Coalescence filter unit			2
6	Automatic closure device	D250 (0.85-0.9g/cm ³)		1
5	Ventilation outlet	D110		1
4	TEGRA 1000/600 cone	D1100/600 H=650 mm		1
3	Outlet sewer	D160		1
	Spigot D250 with Coupler D250 and reducers D250/200 and D200/160			
2	Inlet sewer	D160		1
	Spigot D250 with Coupler D250 and reducers D250/200 and D200/160			
1	CERTARO NS6/2000 sand and oil separator	Length of tank: 2800		1
	Flow capacity class-1: 6 l/s	Height of tank: 1978		
	Material PE-MD, pH 3-10/Heat endurance max. 50°C	Width of tank: 2040		
	V Total (wet) volume	4550 l		
	Vo Oil storage in filter box: 238 liter and in total:	1040 l		
	Vs Sludge volume	2000 l		

Title: CERTARO NS6/2000 sand and oil separator (3031394)			Drawing type: CUSTOMER DRAWING	
Design by: AL/JS	Approved by: TaP 20.04.18	Drawing no.: 23KB15_r	Date: 20.04.2018	Scale:
Construction site:			wavin CONNECT TO BETTER	
			Wavin Sweden Kjulanon 6 SE-63506 ESKILSTUNA www.wavin.se wavin.se@wavin.com +46 (0) 16 - 541 0000	

This drawing and the technical information included in the drawing are property of Wavin-Labko. All the national regulations concerning this product have to be checked before purchase of the product. Installation have to be done according to installation manual.