

Nominal flow rate: 10 l/s
Max. flow rate: 100 l/s

9	ACCESSORY: Double socket in separator line (D160), 2 pcs	(x)	<input type="checkbox"/>
8	ACCESSORY: Double socket (D400), 4 pcs	(x)	<input type="checkbox"/>
7	ACCESSORY: Cover (as needed), 3 pcs	(x)	<input type="checkbox"/>
6	ACCESSORY: TEGRA 600x1.5 m extension shaft with socket (3 pcs)	(x)	<input type="checkbox"/>
	h (1) = 1600...3000 mm	(x)	<input type="checkbox"/>
	h (2) = 1100...3000 mm	<input type="checkbox"/>	<input type="checkbox"/>
	h (3) = 1600...3000 mm	<input type="checkbox"/>	<input type="checkbox"/>

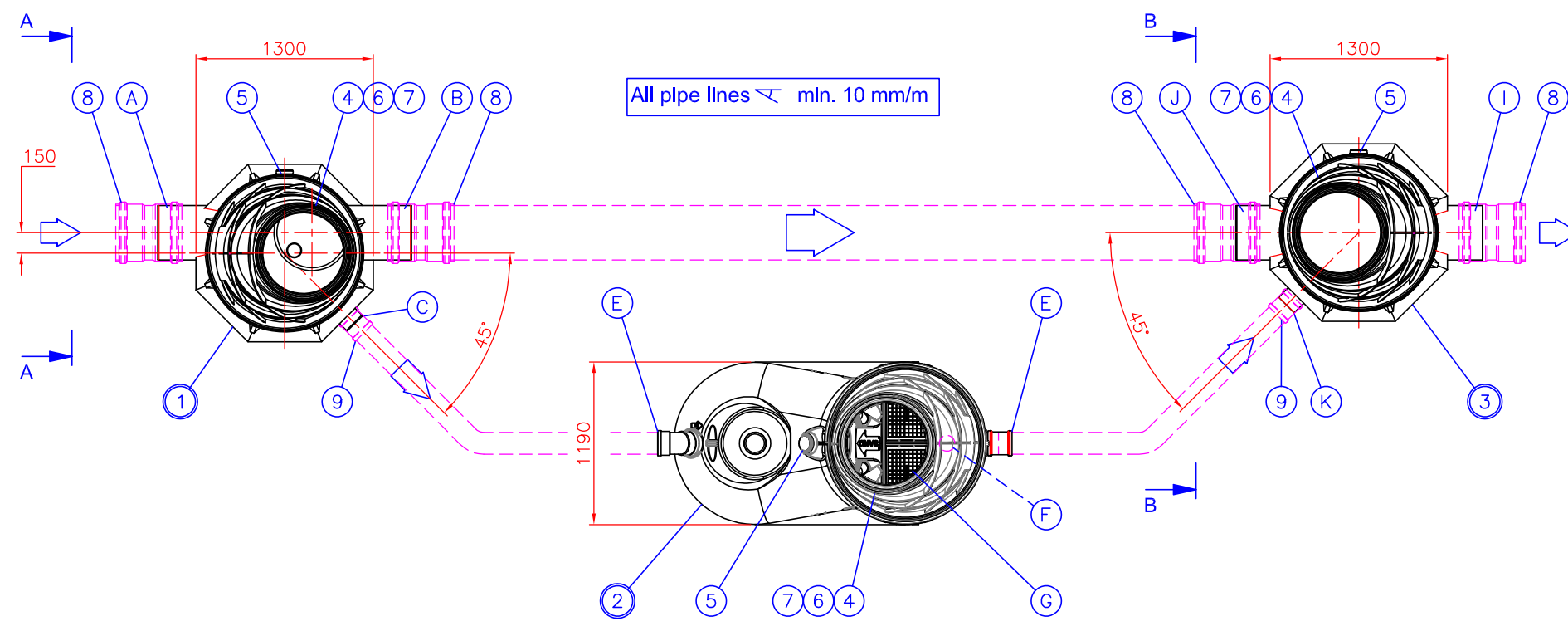



5	Ventilation outlet	D110	3
4	TEGRA 1000 -cover part		3

3	EuroNOK Nordic FRW Basic Tegra Cone DN400/160 Sampling shaft Bottom part. Material: PE-MD Heat endurance max. 50°C	Linked drawing no. 41FB10 ø1160, H~ 1290 mm	1
I	Outlet sewer, PE-HD	D400	
J	By-pass inlet sewer, PE-HD	D400	
K	Inlet from separator, PE-HD	D160	
2	CERTARO NS10/1000 sand and oil separator Material PE-MD, pH 3-10/Heat endurance max. 50°C	Linked drawing no. 23KB02 2290x1190x1625 mm	1
E	Inlet/Outlet sewer	D160 with socket	
F	Automatic closure device	D160 (0.85-0.9g/cm3)	
G	Coalescence filter unit, 2 pcs		
H	Alarm system (central unit with oil surface and blockage detection probes)		
1	Labko FRW Basic Tegra Cone NS10/100 Flow Regulation Well Bottom part. Material: PE-MD Heat endurance max. 50°C	Linked drawing no. 43CB10 ø1160, H~ 1290 mm	1
A	Inlet sewer, PE-HD	D400	
B	By-pass sewer, PE-HD	D400	
C	Outlet sewer for separator, PE-HD	D160	
D	Flow regulator plate	Max. flow 10 l/s	

Maximum SLW60 (100kN/m²) traffic load if 1,0m hard surface coverage above inlet (water level).
Maximum groundwater level 2,5m above bottom of tank.
Max depth is 3,0m from cover down to inlet (water level).

h = Installation height from inlet to ground surface
h (1) = _____ (max. 3000 mm, without TEGRA 600x1.5 M maintenance shaft h (1) = 1600 mm)
h (2) = _____ (max. 3000 mm, without TEGRA 600x1.5 M maintenance shaft h (2) = 1100 mm)
h (3) = _____ (max. 3000 mm, without TEGRA 600x1.5 M maintenance shaft h (3) = 1600 mm)

This drawing and the technical information included in the drawing are property of Wavin-Labko.
All the national regulations concerning this product have to be checked before purchase of the product.
Installation have to be done according to installation manual.

Title: Oil separator system Max. flow 10 l/s		Drawing type CUSTOMER DRAWING	
Design by: AL/JS	Approved by: HT 31.05.2018	Drawing no. 23KG02_r	Date: 31.05.2018
Construction site:		Scale:	
			
		Wavin Sweden Kjulamon 6 SE-63506 ESKILSTUNA www.wavin.se wavin.se@wavin.com +46 (0) 16 - 541 0000	