

Oil and petrol trap for garages

MiniPEK® S 0,4

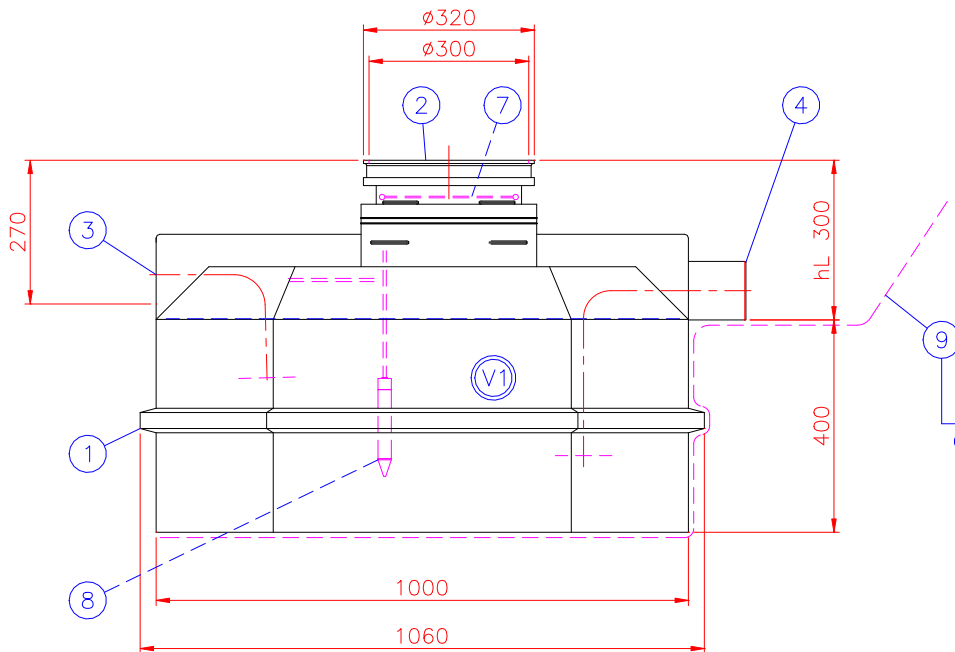

Heating cable (230V) cabel for electricity connection length 5 m

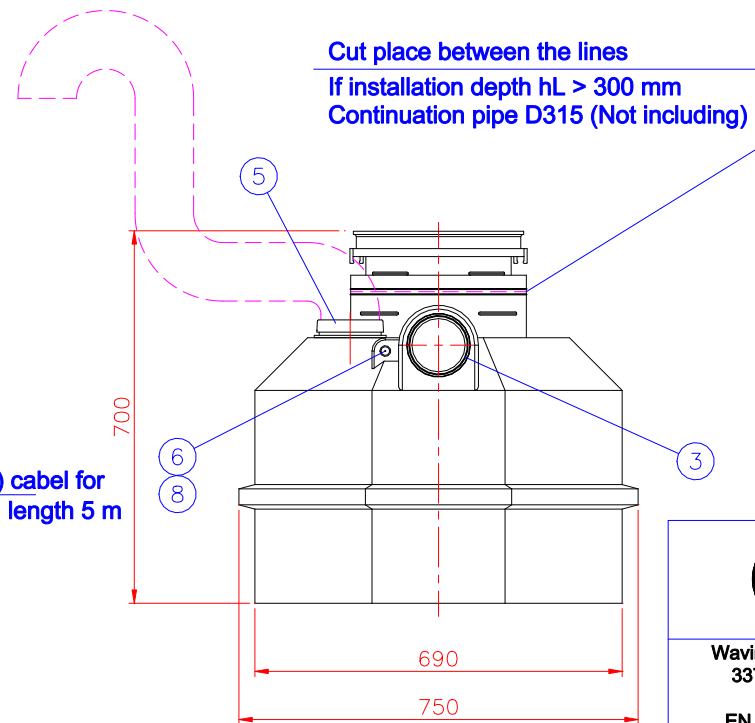

Wavin-Labko Oy, Visiokatu 1
33720 Tampere, Finland
15
EN 858-1:2002 + A1:2004
Separator system for light liquids
NS 0,4
Material: Polyethylene

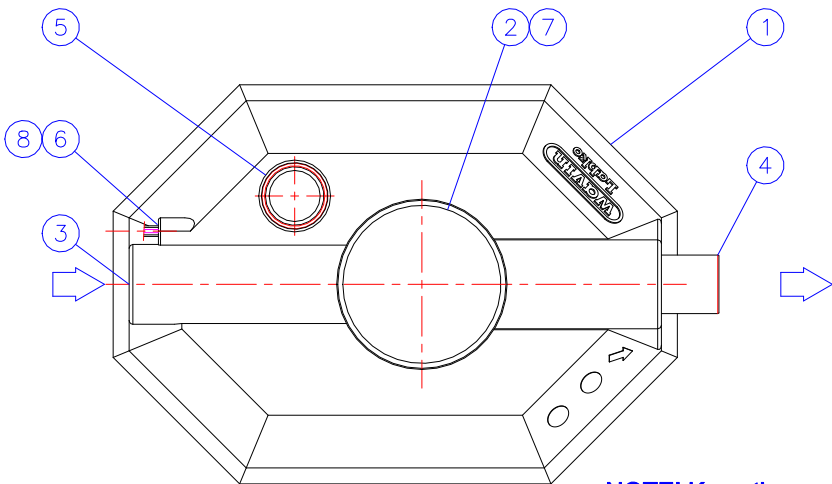

1	Body, PE V1 Area for oil and petrol separation	750x1060, H=700 mm 220 l	1
2	Cover ø300 (solid), Standard EN124	Cover class C250 (25 tn)	1
3	Inlet sewer	D110	1
4	Outlet sewer	D110	1
5	Ventilation outlet	D110	1
6	Inlet for cabel		1

ACCESSORIES:



7	Odour proof cover	(x)	<input type="checkbox"/>
8	Oil alarm unit	(x)	<input type="checkbox"/>
9	Heating cable (230V). Effective 180 W MCMK cabel for electricity (230V) connection length 5 m. Not including insulation	(x)	<input type="checkbox"/>

Weight ca. 31 kg (with C250 cover)

Capacity 0.4 dm³ /s according to D1/1987 for surface load of 5 m³ /hm² and with a delay of 9 min.

Notes: _____

NOTE! Keep the cover of the separator in place during the casting

Title: MiniPEK S 0,4 Oil and petrol trap for garages		Drawing type CUSTOMER DRAWING	
Design by: HT/JS	Approved by: HT 01.03.18	Drawing no. 02HB01ce	Date: 01.03.2018
Construction site:		Scale:	
			
		WAVIN-LABKO Ltd. VISIOKATU 1 FIN-33720 TAMPERE FINLAND tel. +358 20 1285200 fax. +358 20 1285280	

This drawing and the technical information included in the drawing are property of Wavin-Labko. All the national regulations concerning this product have to be checked before purchase of the product. Installation have to be done according to installation manual.