

Nominal flow rate: 20 l/s
Max. flow rate: 200 l/s

9	ACCESSORY: Double socket in separator line (D250), 4 pcs	(x)	<input type="checkbox"/>
8	ACCESSORY: Double socket (D400), 4 pcs	(x)	<input type="checkbox"/>
7	ACCESSORY: Cover (as needed), 3 pcs	(x)	<input type="checkbox"/>
6	ACCESSORY: TEGRA 600x1.5 m extension shaft with socket (3 pcs)	(x)	<input type="checkbox"/>
	h (1) = 1600...3000 mm	(x)	<input type="checkbox"/>
	h (2) = 1270...3000 mm	<input type="checkbox"/>	<input type="checkbox"/>
	h (3) = 1600...3000 mm	<input type="checkbox"/>	<input type="checkbox"/>

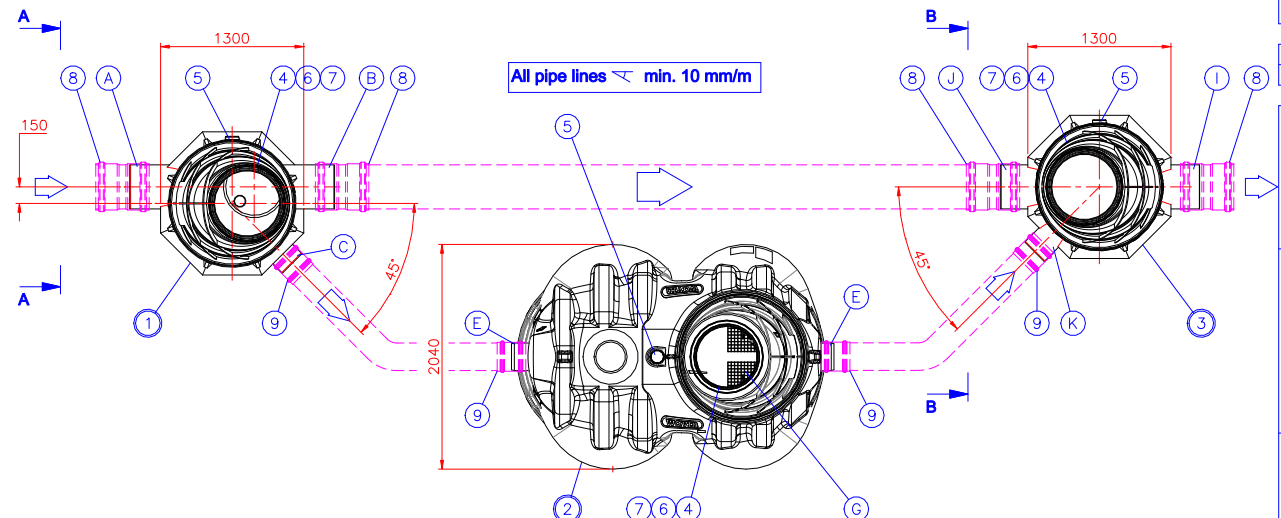

5	Ventilation outlet	D110	3
4	TEGRA 1000 -cover part		3

3	EuroNOK Nordic FRW Basic Tegra Cone DN400/250 Sampling shaft Bottom part. Material: PE-MD Heat endurance max. 50°C	Linked drawing no. 41FB10	1
	l	Outlet sewer, PE-HD	D400
	J	By-pass inlet sewer, PE-HD	D400
	K	Inlet from separator, PE-HD	D250
2	CERTARO NS20/2000 sand and oil separator Material PE-MD, pH 3-10/Heat endurance max. 50°C	Linked drawing no. 23LB02	1
	E	Inlet/Outlet sewer, Spigot	D250
	F	Automatic closure device	D250 (0.85-0.9g/cm ³)
	G	Coalescence filter unit, 2 pcs	D250
	H	Alarm system (central unit with oil surface and blockage detection probes)	
1	Labko FRW Basic Tegra Cone NS20/200 Flow Regulation Well Bottom part. Material: PE-MD Heat endurance max. 50°C	Linked drawing no. 43CB10	1
	A	Inlet sewer, PE-HD	D400
	B	By-pass sewer, PE-HD	D400
	C	Outlet sewer for separator, PE-HD	D250
	D	Flow regulator plate	Max. flow 20 l/s

Maximum SLW60 (100kN/m²) traffic load if 1,0m hard surface coverage above inlet (water level).
Maximum groundwater level 2,5m above bottom of tank.
Max depth is 3,0m from cover down to inlet (water level).

h = Installation height from inlet to ground surface
h (1) = _____ (max. 3000 mm, without TEGRA 600x1.5 M maintenance shaft h (1) = 1600 mm)
h (2) = _____ (max. 3000 mm, without TEGRA 600x1.5 M maintenance shaft h (2) = 1270 mm)
h (3) = _____ (max. 3000 mm, without TEGRA 600x1.5 M maintenance shaft h (3) = 1600 mm)

Title: Oil separator system Max. flow 20 l/s			Drawing type CUSTOMER DRAWING	
Design by: ALJS	Approved by: TaP 03.05.18	Drawing no. 23LG01_r	Date: 03.05.2018	Scale:
Construction site:			 Wavin Sweden Kjulemon 6 SE-63606 ESKILSTUNA www.wavin.se wavin.se@wavin.com +46 (0) 16 - 541 0000	

This drawing and the technical information included in the drawing are property of Wavin-Labko. All the national regulations concerning this product have to be checked before purchase of the product. Installation have to be done according to installation manual.