

**CERTARO NS20/2000 sand and oil separator with TEGRA 600x1.5 M maintenance shaft**  
**h = 1270 ... 3000 mm**

(X)

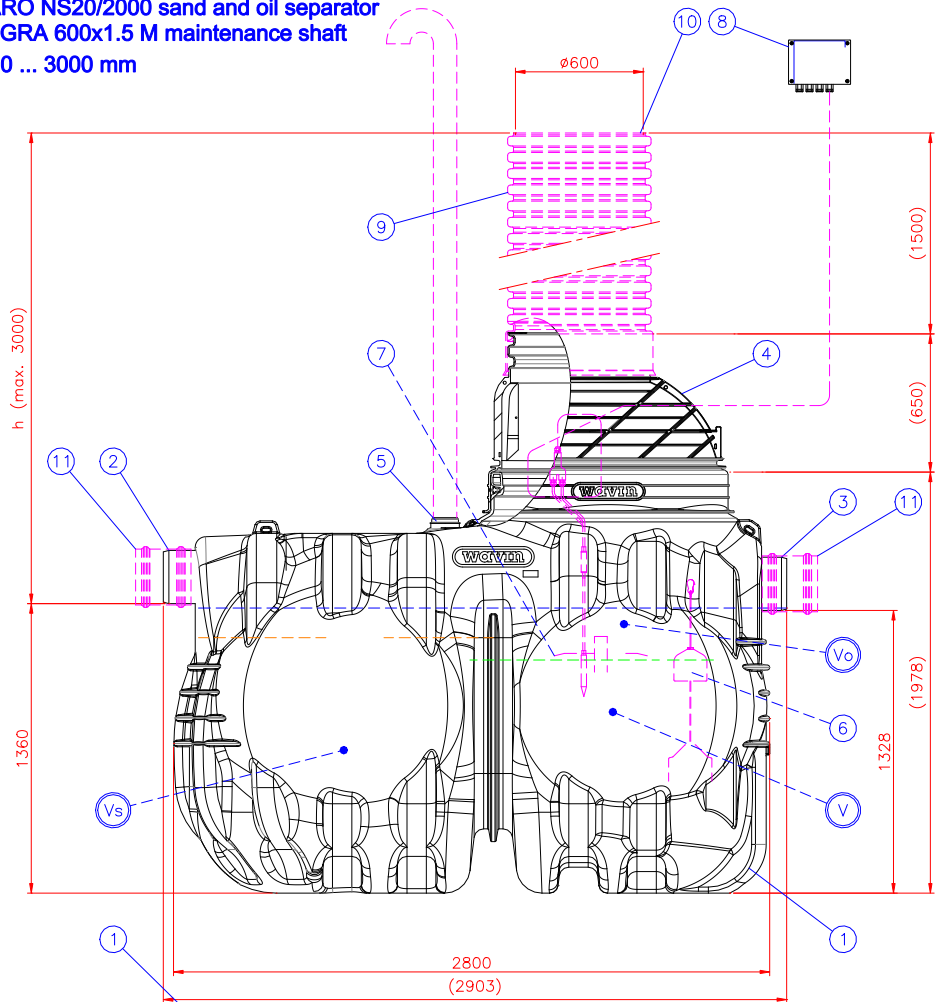

**CERTARO NS20/2000 sand and oil separator without TEGRA 600x1.5 M maintenance shaft**  
**h = 1270 mm**

(X)

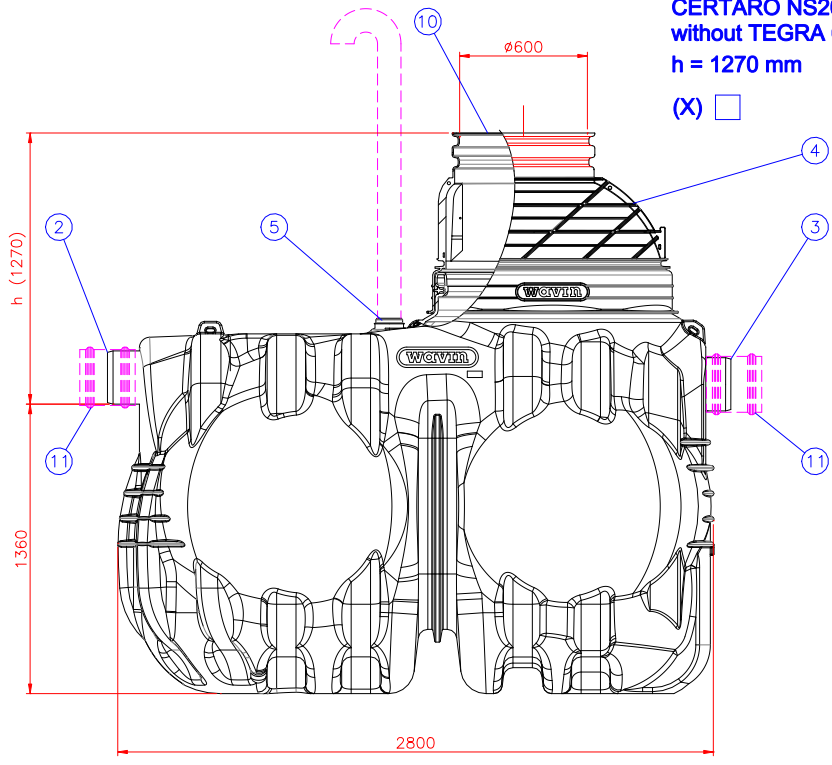

**Maximum SLW60 (100kN/m<sup>2</sup>) traffic load if 1,0m hard surface coverage above inlet (water level).  
 Maximum groundwater level 2,5m above bottom of tank.  
 Max depth is 3,0m from cover down to inlet (water level).**

**h = Installation height from inlet to ground surface**

**h = \_\_\_\_\_ (max. 3000 mm)**

**Weight 350 kg**

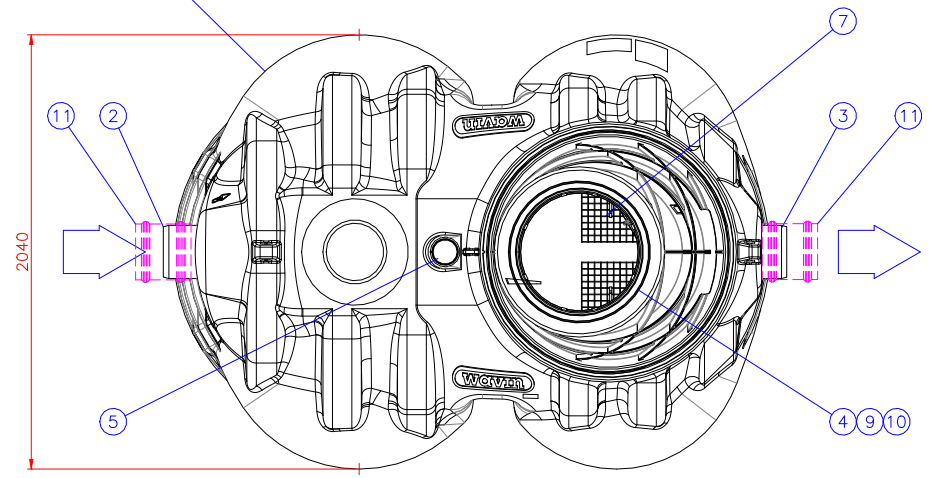

11	ACCESSORY: Double socket in inlet and outlet sewer D250, 2 pcs	(x)	<input type="checkbox"/>
10	ACCESSORY: Cover (as needed)	(x)	<input type="checkbox"/>
9	ACCESSORY: TEGRA 600 maintenance shaft with socket and 600 sealing ring height 1500 mm	(x)	<input type="checkbox"/>
8	Alarm system (central unit with oil surface and blockage detection probes)		
7	Coalescence filter unit		2
6	Automatic closure device	D250 (0.85–0.9g/cm <sup>3</sup> )	1
5	Ventilation outlet	D110	1
4	TEGRA 1000/600 cone	D1100/600 H=650 mm	1
3	Outlet sewer, Spigot	D250	1
2	Inlet sewer, Spigot	D250	1
1	CERTARO NS20/2000 sand and oil separator	Length of tank: 2800 Height of tank: 1978 Width of tank: 2040	1
	Material PE-MD, pH 3–10/Heat endurance max. 50°C		
V	Total (wet) volume	4550 l	
Vo	Oil storage in filter box: 238 liter and in total:	1040 l	
Vs	Sludge volume	2000 l	

<b>Title:</b> CERTARO NS20/2000 sand and oil separator (3031347)		<b>Drawing type:</b> CUSTOMER DRAWING	
<b>Design by:</b> AL/JS	<b>Approved by:</b> HT 19.04.2018	<b>Drawing no.:</b> 23LB02_r	<b>Date:</b> 19.04.2018
<b>Construction site:</b>		<b>Scale:</b>	



**WAVIN**  
 Kjölemon 6  
 SE-63506 ESKILSTUNA  
 www.wavin.se  
 wavin.se@wavin.com  
 +46 (0) 16 - 541 0000

This drawing and the technical information included in the drawing are property of Wavin-Labko. All the national regulations concerning this product have to be checked before purchase of the product. Installation have to be done according to installation manual.