

CERTARO NS 6 / 600 sand and oil separator with TEGRA 600x1.5 M maintenance shaft
h = 1100 ... 3000 mm

(X)

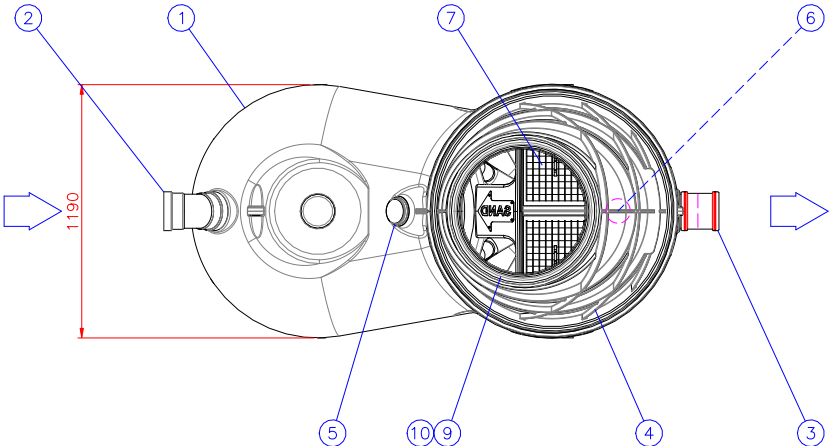
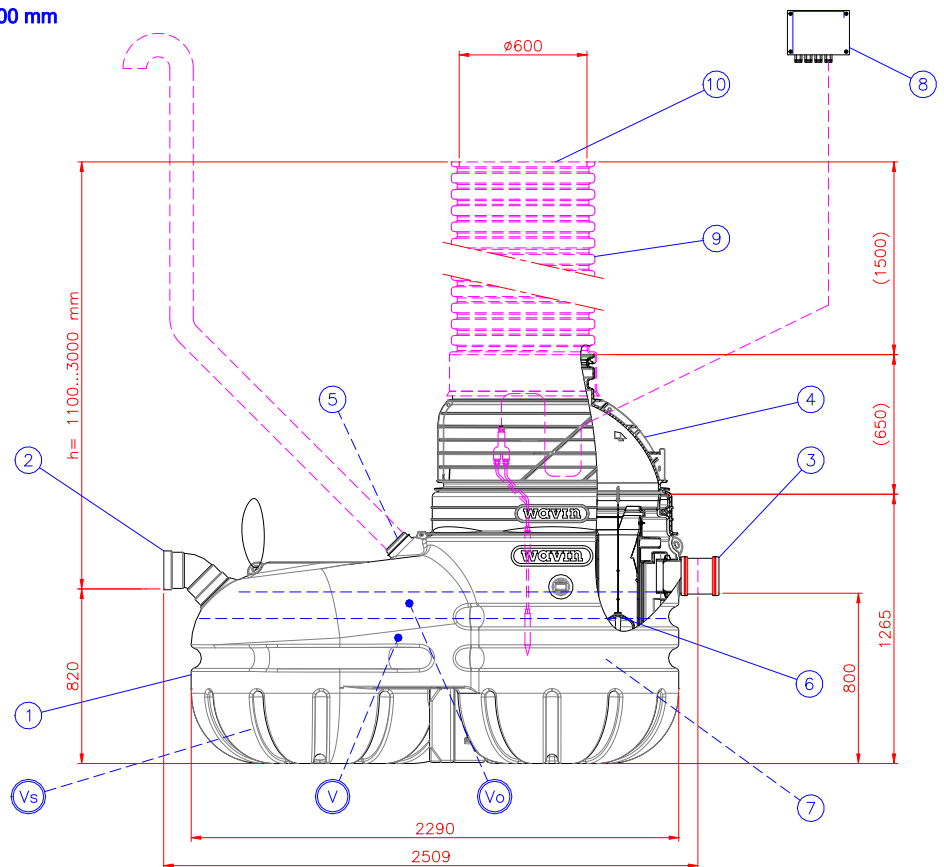

h = Installation height from inlet to ground surface
h = _____ (1100 - 3000 mm)

CERTARO NS 6 / 600 sand and oil separator without TEGRA 600x1.5 M maintenance shaft
h = 1100 mm

(X)

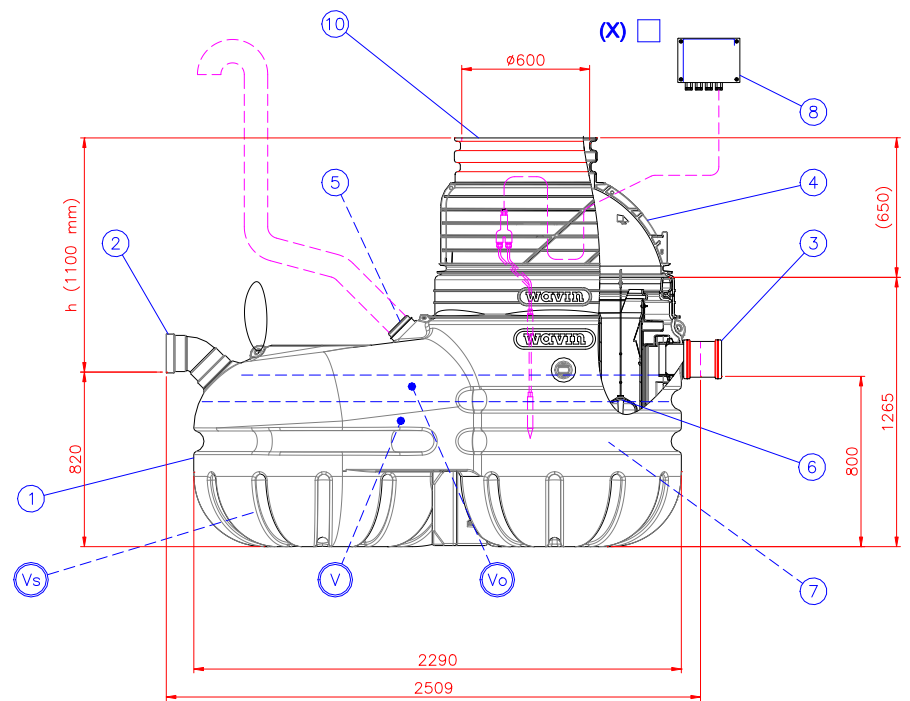

Maximum SLW60 (100kN/m²) traffic load if 1,0m hard surface coverage above inlet (water level).
Maximum groundwater level 2,5m above bottom of tank.
Maximum depth is 3,0m from cover down to inlet (water level).

Weight 260 kg

10	ACCESSORY: Cover (as needed)		(x) <input type="checkbox"/>
9	ACCESSORY: TEGRA 600 maintenance shaft with socket and 600 sealing ring height 1500 mm		(x) <input type="checkbox"/>
8	Alarm system (central unit with oil surface and blockage detection probes)		
7	Coalescence filter unit		2
6	Automatic closure device	D160 (0.85–0.9g/cm ³)	1
5	Ventilation outlet	D110	1
4	TEGRA 1000/600 cone	D1100/600 H=650 mm	1
3	Outlet sewer	D160	1
	D160 spigot with Coupler D160		
2	Inlet sewer (with Socket)	D160	1
	D160 spigot with Coupler/Bend D160–45°		
1	CERTARO NS6/600 sand and oil separator	Length of tank: 2290	1
	Flow capacity class-1: 6 l/s	Height of tank: 1265	
	Material PE-MD, pH 3–10/Heat endurance max. 50°C	Width of tank: 1190	
	V Total (wet) volume	1404 l	
	Vo Oil storage in filter box: 64.2 liter and in total:	290 l	
	Vs Sludge volume	600 l	

Title: CERTARO NS6/600 sand and oil separator (3031087)		Drawing type: CUSTOMER DRAWING	
Design by: AL/JS	Approved by: HT 27.04.2018	Drawing no.: 23KB01cr	Date: 27.04.2018
Construction site:		Scale:	
		Wavin Sweden Kjölemon 6 SE-63506 ESKILSTUNA www.wavin.se wavin.se@wavin.com +46 (0) 16 - 541 0000	
		CONNECT TO BETTER	

This drawing and the technical information included in the drawing are property of Wavin-Labko. All the national regulations concerning this product have to be checked before purchase of the product. Installation have to be done according to installation manual.