

CERTARO NS15/2000 sand and oil separator with TEGRA 600x1.5 M maintenance shaft

h = 1270 ... 3000 mm

(X)

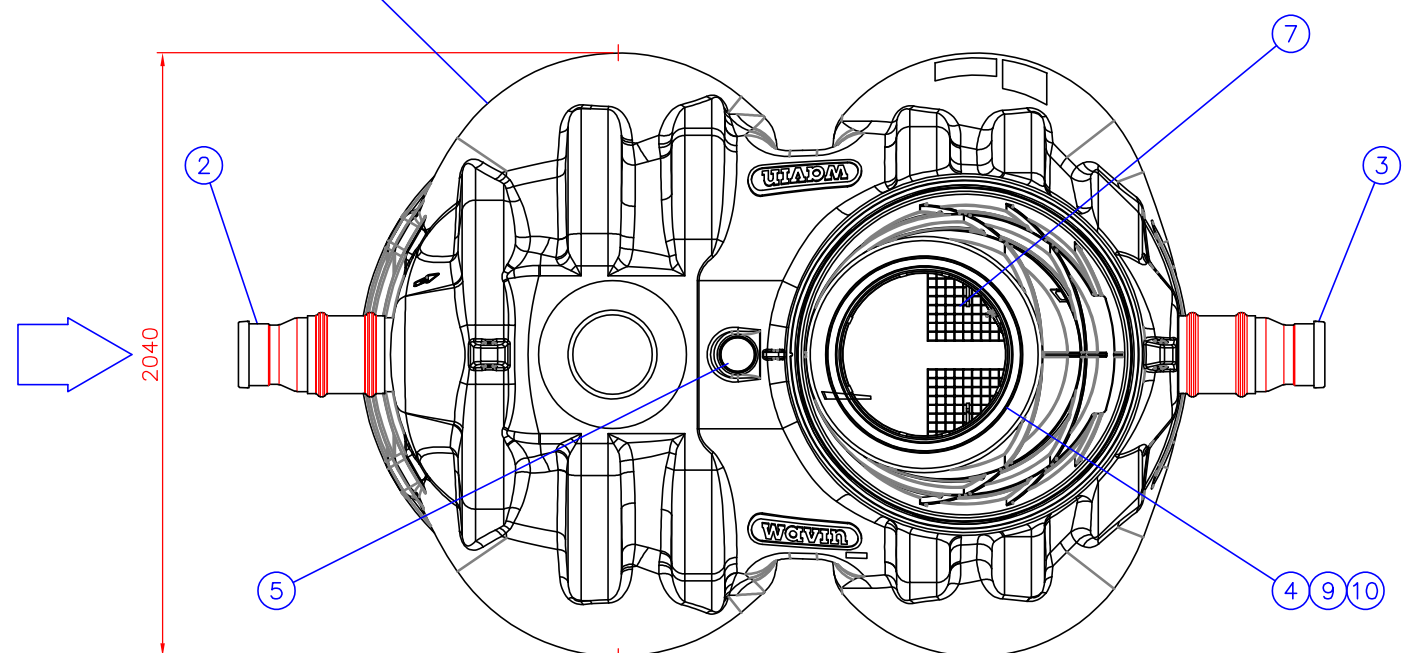
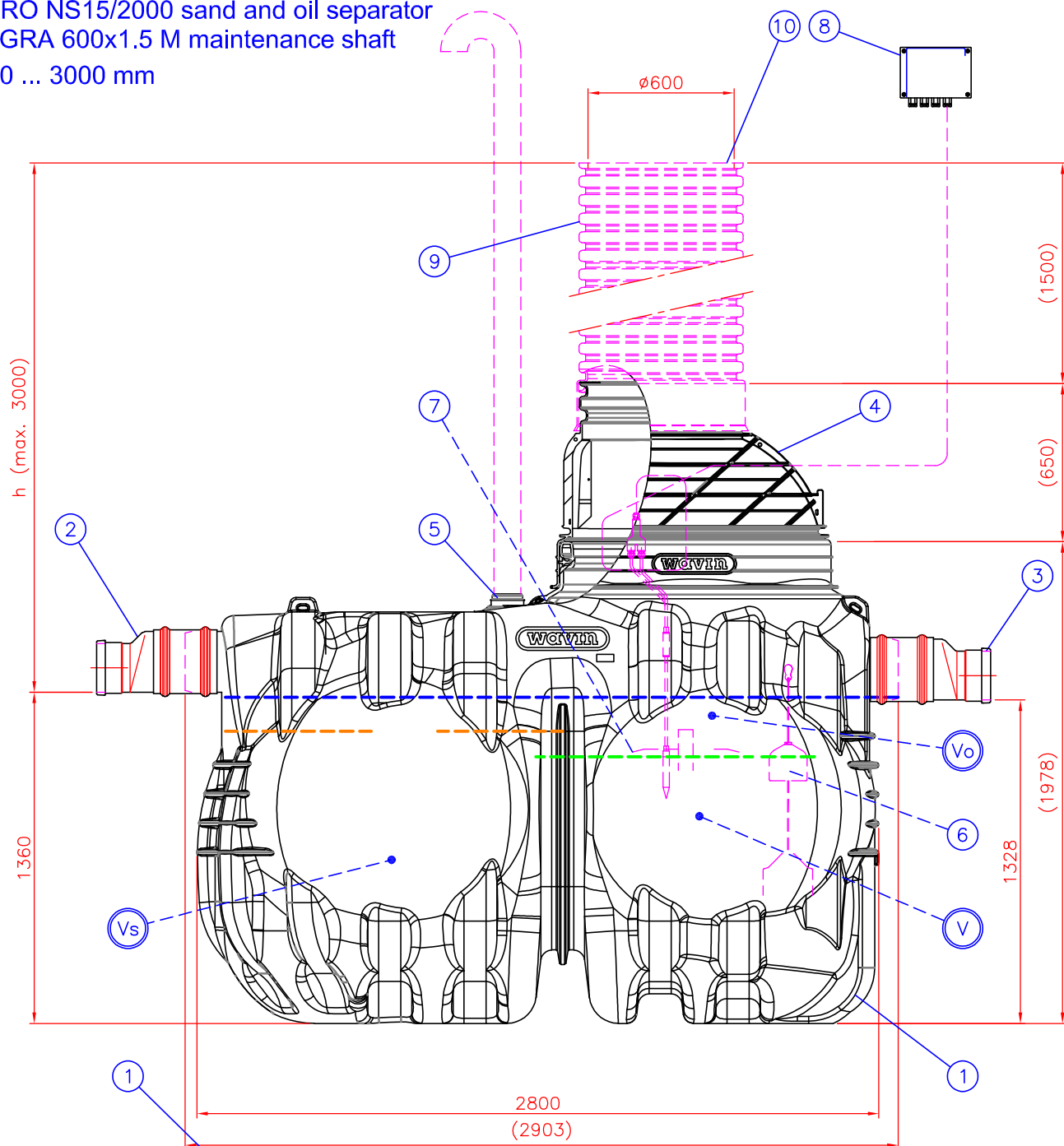

CERTARO NS15/2000 sand and oil separator without TEGRA 600x1.5 M maintenance shaft

h = 1270 mm

(X)

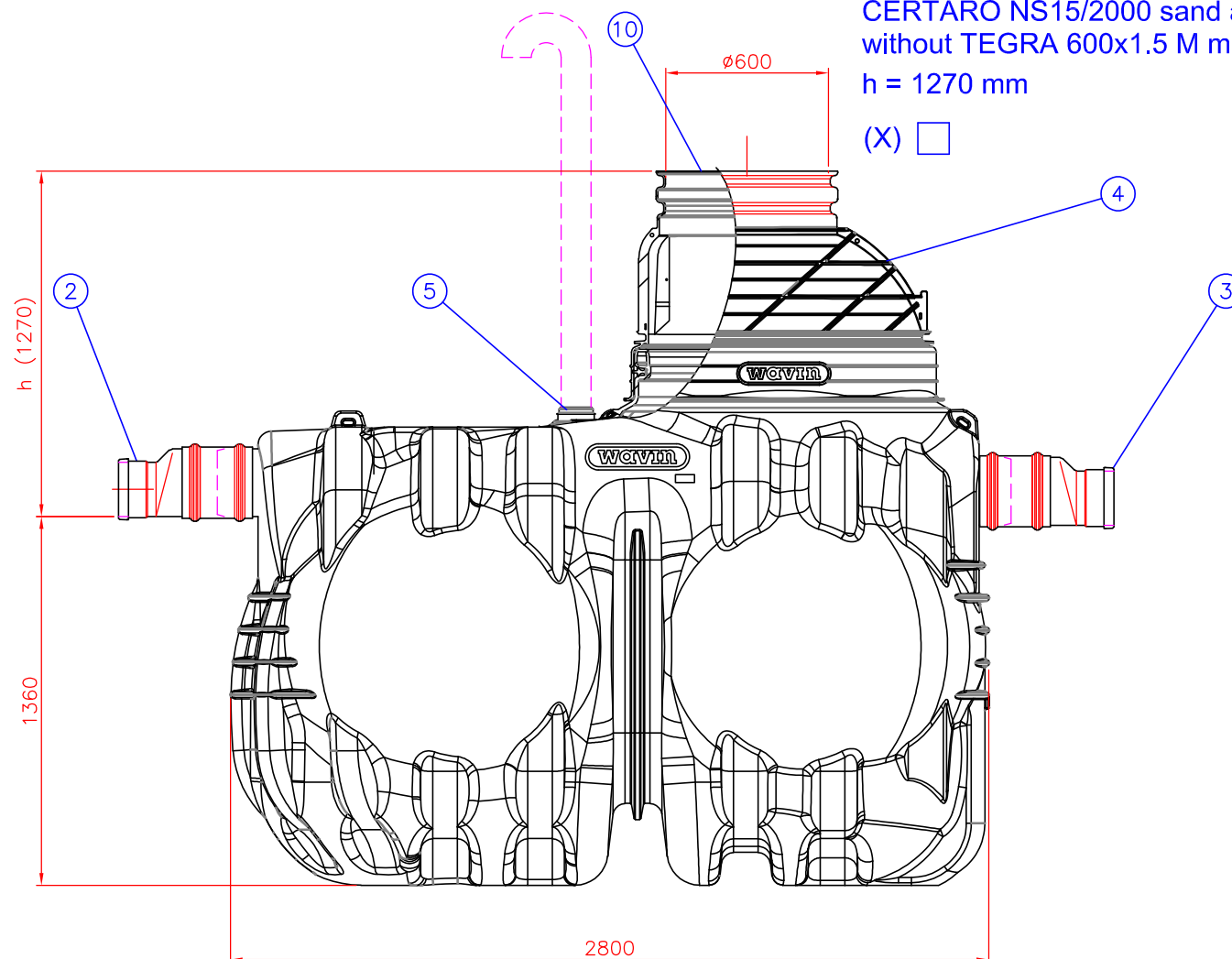



Maximum SLW60 (100kN/m²) traffic load if 1,0m hard surface coverage above inlet (water level).
Maximum groundwater level 2,5m above bottom of tank.
Max depth is 3,0m from cover down to inlet (water level).

h = Installation height from inlet to ground surface

h = _____ (max. 3000 mm)

Weight 350 kg

10	ACCESSORY: Cover (as needed)		(x) <input type="checkbox"/>
9	ACCESSORY: TEGRA 600 maintenance shaft with socket and 600 sealing ring height 1500 mm		(x) <input type="checkbox"/>
8	Alarm system (central unit with oil surface and blockage detection probes)		
7	Coalescence filter unit		2
6	Automatic closure device	D250 (0.85–0.9g/cm ³)	1
5	Ventilation outlet	D110	1
4	TEGRA 1000/600 cone	D1100/600 H=650 mm	1
3	Outlet sewer	D200	1
	Spigot D250 with Coupler D250 and reducer D250/200		
2	Inlet sewer	D200	1
	Spigot D250 with Coupler D250 and reducer D250/200		
1	CERTARO NS15/2000 sand and oil separator	Length of tank: 2800	1
	Flow capacity class-1: 15 l/s	Height of tank: 1978	
	Material PE-MD, pH 3–10/Heat endurance max. 50°C	Width of tank: 2040	
	V Total (wet) volume	4550 l	
	Vo Oil storage in filter box: 238 liter and in total:	1040 l	
	Vs Sludge volume	2000 l	

Title:		Drawing type	
CERTARO NS15/2000 sand and oil separator (3031340)		CUSTOMER DRAWING	
Design by:	Approved by:	Drawing no.	Date:
AL/JS	HT 20.04.2018	23LB01_r	20.04.2018
Construction site:		Scale:	
			
		Wavin Sweden Kjulamön 6 SE-63506 ESKILSTUNA www.wavin.se wavin.se@wavin.com +46 (0) 16 - 541 0000	