

# HEK® 40 LK sand and sludge separator

is used in car repair shops, parking areas and garages (max. 2 cars per shaft).

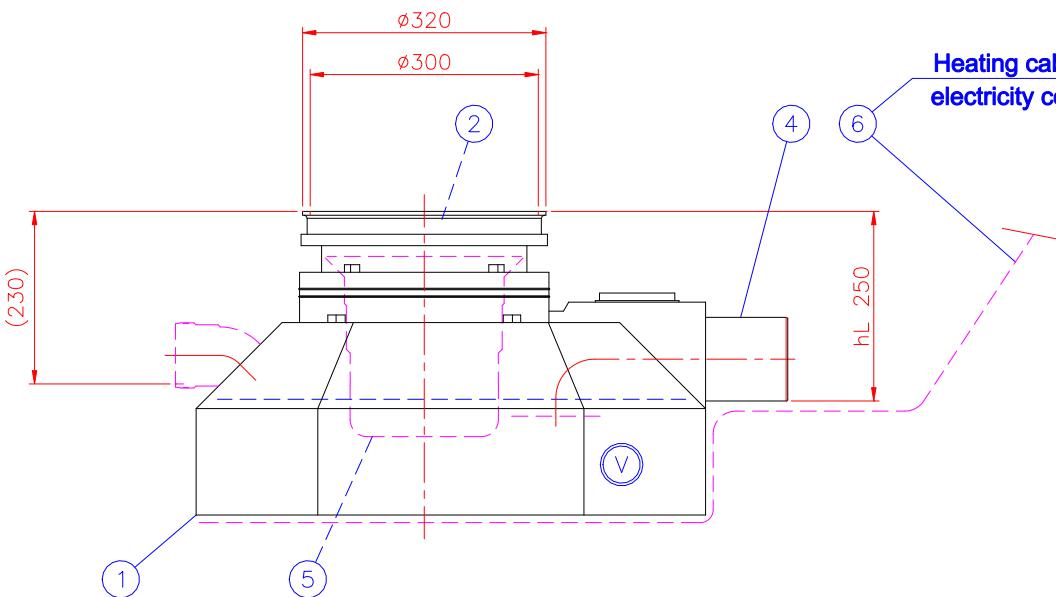

Cut place between the lines  
If installation depth hL > 250 mm  
Continuation pipe D315 (Not including)

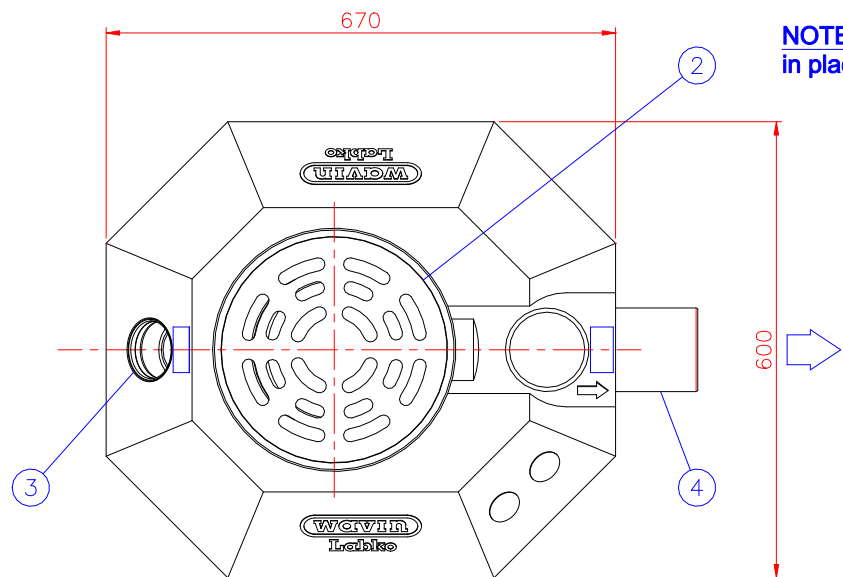
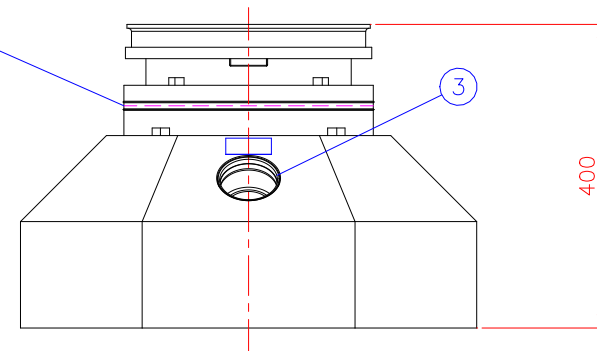

**NOTE!** Keep the cover of the separator in place during the casting

Weight ca. 17 kg (with B125 cover)

1	Body, material PE-MD V   Storage volume for sludge	600x670, H=400 mm 40 l (20 l / parking space)	1
2	Rain water cover Ø300, Standard EN124 (standard delivery with B125 cover) Cover class B125 (12.5 tn) Cover class C250 (25 tn) (x) <input type="checkbox"/>		1
3	Inlet sewer (option)	D75 (openable)	1
4	Outlet sewer	D110	1
5	Bucket for sludge	Ø260 H=240 mm	1

ACCESSORIES:			
6	Heating cable (230V). Effective 180 W	(x) <input type="checkbox"/>	
	MCMK cabel for electricity (230V) connection length 5 m. Not including insulation		

Title: <b>HEK 40 LK Sand and sludge trap</b>		Drawing type <b>CUSTOMER DRAWING</b>	
Design by: <b>HT/JS</b>	Approved by: <b>HT 06.02.2018</b>	Drawing no. <b>01AB03ee</b>	Date: <b>06.02.2018</b>
Construction site:		Scale:	
		WAVIN-LABKO Ltd. VISIOKATU 1 FIN-33720 TAMPERE FINLAND tel. +358 20 1285200 fax. +358 20 1285280	

This drawing and the technical information included in the drawing are property of Wavin-Labko. All the national regulations concerning this product have to be checked before purchase of the product. Installation have to be done according to installation manual.