

Det. A – A:

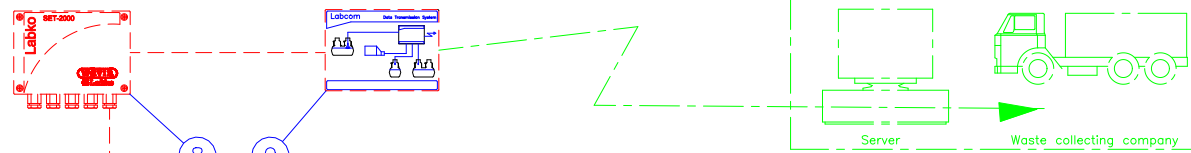
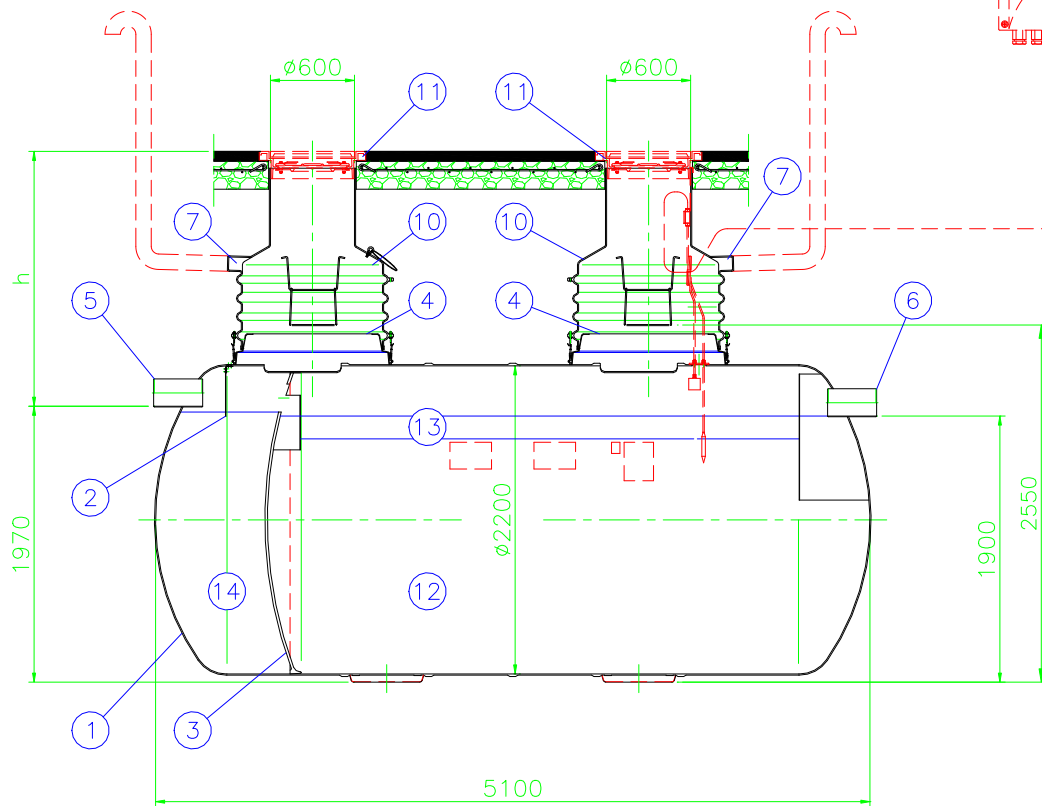

h=Vattengång inlopp till färdig mark (Max. 2500 mm)

h= \_\_\_\_\_ mm

Max. flöde: 25 l/s

Dimensionering: Enligt EN 1825  
Förlängningshalsar: EuroHUK 600 (2 st)

14	Lagringsvolym slam		2630 l	
13	Lagringsvolym fett		1400 l	
12	Effektiv volym		13820 l	
11	EXTRA UTRUSTNING: Gjutjärnsbetäckning $\varnothing 600$ (2 st)			
	Lock A15 (1.5 tn) + ram (x) <input type="checkbox"/>			
	Lock C250 (25 tn) + ram <input type="checkbox"/>			
	Lock D400 (40 tn) + ram <input type="checkbox"/>		Art. nr: 8533022	
10	EXTRA UTRUSTNING: PP-HUK Förhöjningshals, material: PE-MD h=Vattengång inlopp till färdig mark (Max. 2500 mm)			(2)
	EuroHUK 600 h 9-13 (x) <input type="checkbox"/>	h= 900...1300 mm.	Art. nr: 8531009	
	EuroHUK 600 h13-17 <input type="checkbox"/>	h=1300...1700 mm.	Art. nr: 8531013	
	EuroHUK 600 h17-21 <input type="checkbox"/>	h=1700...2100 mm.	Art. nr: 8531014	
	EuroHUK 600 h21-25 <input type="checkbox"/>	h=2100...2500 mm.	Art. nr: 8531021	
9	EXTRA UTRUSTNING: LABCOM kommunikationsenhet (x) <input type="checkbox"/>			
8	EXTRA UTRUSTNING: Nivåalarm SET-2000 med SET DM/3 och SET/OS2 givare (x) <input type="checkbox"/>			
7	Ventilation utlopp	PE	Dy110	2
6	Utlopp	PVC	Dy200	1
5	Inlopp	PVC	Dy200	1
4	Krage för EuroHUK 600	GAP	D1000	2
3	Mellanvägg	GAP	D2200	1
2	Inloppsskärm	GAP		1
1	Material: GAP "Lasa Komposit", pH 3-10/max temp 80°C		$\varnothing 2200$ L=5100 mm	1

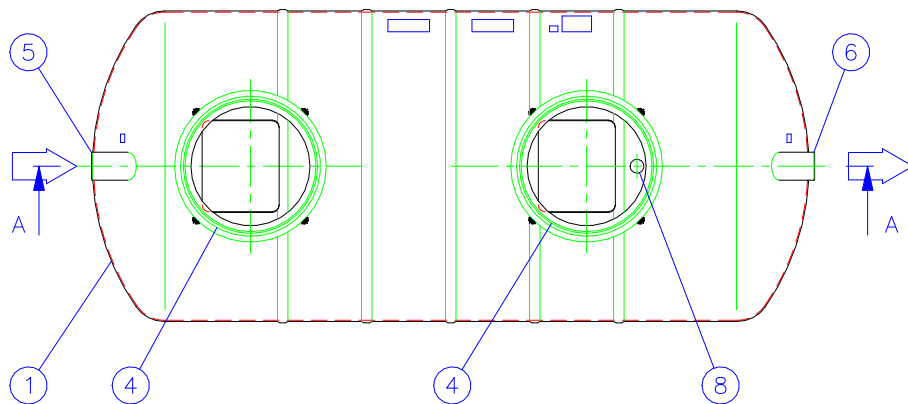

This drawing and the technical information included in the drawing are property of Wavin-Labko Ltd. This drawing can not be shown to a third party without the consent of Wavin-Labko Ltd.

Godkänd av:  
\_\_\_\_ / \_\_\_\_ 200\_\_



Wavin  
Kjulamon 6  
S-635 06 ESKILSTUNA  
SVERIGE  
Tel 016 - 541 00 00  
Fax. 016 - 541 00 01

Projekt:  
SVERIGE

Artikelnummer	Produkt namn: EuroFAM NS25 fettavskiljare med slamdel (EN1825)	Ritning typ: KUNDRITNING
Designerad av: TiS/JS	Granskad av:	Godkänd av: HT 29.11.05
Arbetsnummer: 320B01br	Datum: 29.11.05	Skala: