

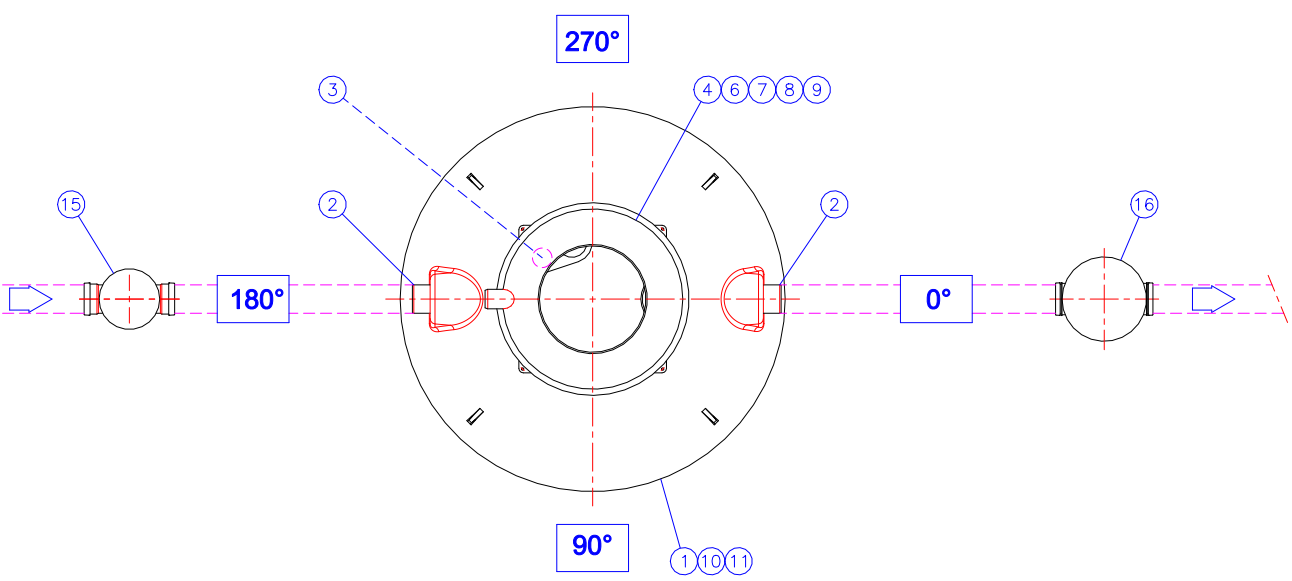

All pipes ∇ min. 10 mm/m



1	EuroREK Omega grease separator (EN1825) NS7 (x) <input type="checkbox"/> Max. flow rate 7 l/s NS10 <input type="checkbox"/> Max. flow rate 10 l/s PE-MD body \varnothing 2170 (ball) temperature endurance max. 50°C	1
	V Total volume 4180 l Vg Grease storage capacity 400 l (H=150 mm) Vs Sludge storage capacity 1000 l	
2	Inlet / Outlet sewer D160	1/1
3	Grease alarm unit	1
4	Maintenance shaft D600/1000, material PE-MD Indoor installation model (Under the floor) h = 500-1000 mm (x) <input type="checkbox"/> Separator with solid HUK 600 maintenance shaft Ground installation model, h = 900-1300...2100-2500 mm h = installation depth of separator from ground surface (mm) h= 900...1300 mm (x) <input type="checkbox"/> h=1300...1700 mm <input type="checkbox"/> h=1700...2100 mm <input type="checkbox"/> h=2100...2500 mm <input type="checkbox"/> h = _____ mm (Max. 2500 mm)	1
5	Ventilation outlet (as needed) D110	1
6	Floating adjustable cast iron lid set \varnothing 600. Standard EN124 Frame for two covers (also for the inner cover) Cover class A15 (1.5 tn) (x) <input type="checkbox"/> Cover class D400 (40 tn) (x) <input type="checkbox"/> Cover class C250 (25 tn) <input type="checkbox"/>	1

ACCESSORIES:		
7	Inner cover (gas proof) (x) <input type="checkbox"/>	
8	Ladder in maintenance shaft, material Al (x) <input type="checkbox"/>	
9	Heating cable set for maintenance shaft (230V). Effective 150 W MCMK cable for electricity (230V) connection length 5 m. Including insulation inner cover. Not including frost insulation (x) <input type="checkbox"/>	
10	ACCESSORY: Anchoring belt (Polyester), weight capacity 1000 kg, 4 pcs (x) <input type="checkbox"/>	
11	Anchoring plates package, GRP, 4 pcs (x) <input type="checkbox"/>	
12	Data transfer unit (x) <input type="checkbox"/>	
13	Emptying pipe with flange DN80 (PN10), PVC (x) <input type="checkbox"/> Degree angle in separator: _____	
14	Imbox quick coupling box for 1 pc. DN80 Suction pipes (x) <input type="checkbox"/>	
15	Inspection chamber D200/160 (x) <input type="checkbox"/>	
16	Wavin NOK D425/D160 sampling shaft (x) <input type="checkbox"/>	

Title: EuroREK Omega NS7 and NS10 Grease separator (EN1825)			Drawing type CUSTOMER DRAWING	
Design by: HT/JS	Approved by: TaP 22.02.18	Drawing no. 32GB05be	Date: 22.02.2018	Scale:
Construction site:			 WAVIN-LABKO Ltd. VISIÖKATU 1 FIN-33720 TAMPERE FINLAND tel. +358 20 1285200 fax. +358 20 1285280	

This drawing and the technical information included in the drawing are property of Wavin-Labko.
All the national regulations concerning this product have to be checked before purchase of the product.
Installation have to be done according to installation manual.