

EuroREK NS2 SL (EN1825)
grease separator (indoor installation,
on the floor)
Max. flow rate 2 l/s

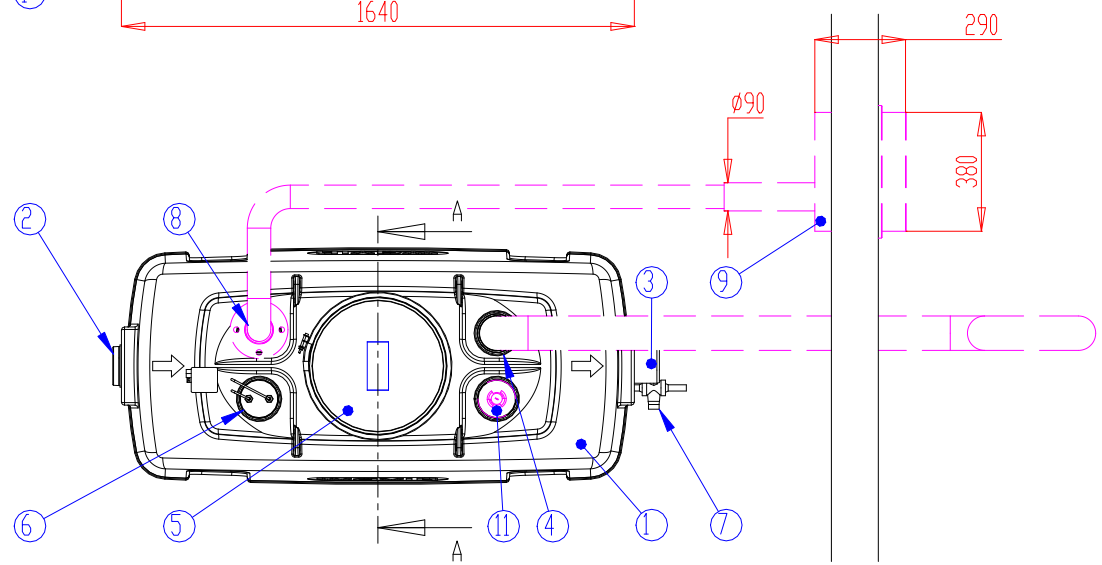

C	Grease storage capacity		80 l	
B	Effective capacity		700 l	
A	Sludge capacity		200 l	
11	ACCESSORY: Washing nozzle (x)			(1)
10	ACCESSORY: Labcom data transfer unit (x)			(1)
9	ACCESSORY: Imubox quick coupling box (x)			(1)
8	ACCESSORY: Emptying pipe with flange (DN80) (x)			(1)
7	Sampling valve			1
6	Grease alarm unit			1
5	Lockable gas tight cover		D400	1
4	Ventilation outlet	PVC	D110	1
3	Outlet sewer	PE	D110	1
2	Inlet sewer	PVC	D110	1
1	Tank (pH3-10/Heat endurance max. 50°C)	PE-MD	1640 x 750 x 1670 mm	1

Product: EuroREK NS2 SL Grease separator (indoor) Drawing type: CUSTOMER DRAWING
 Design by: HT/TL Approved by: HT 07.07.2016 Drawing no: 32AB06ee Date: 06.07.2016 Scale (A4): 1:25

WAVIN-LABKO Ltd.
Labkotie 1
FIN-36240 KANGASALA
FINLAND
puh. +358 020 1285 200
fax. +358 0201285 280

Construction site:

This drawing and the technical information included in the drawing are property of Wavin-Labko Ltd. Authorities' regulations must be known before providing the product. Products must be installed according to installation instructions.