

Connection sewer min. ∇ 10 mm/m

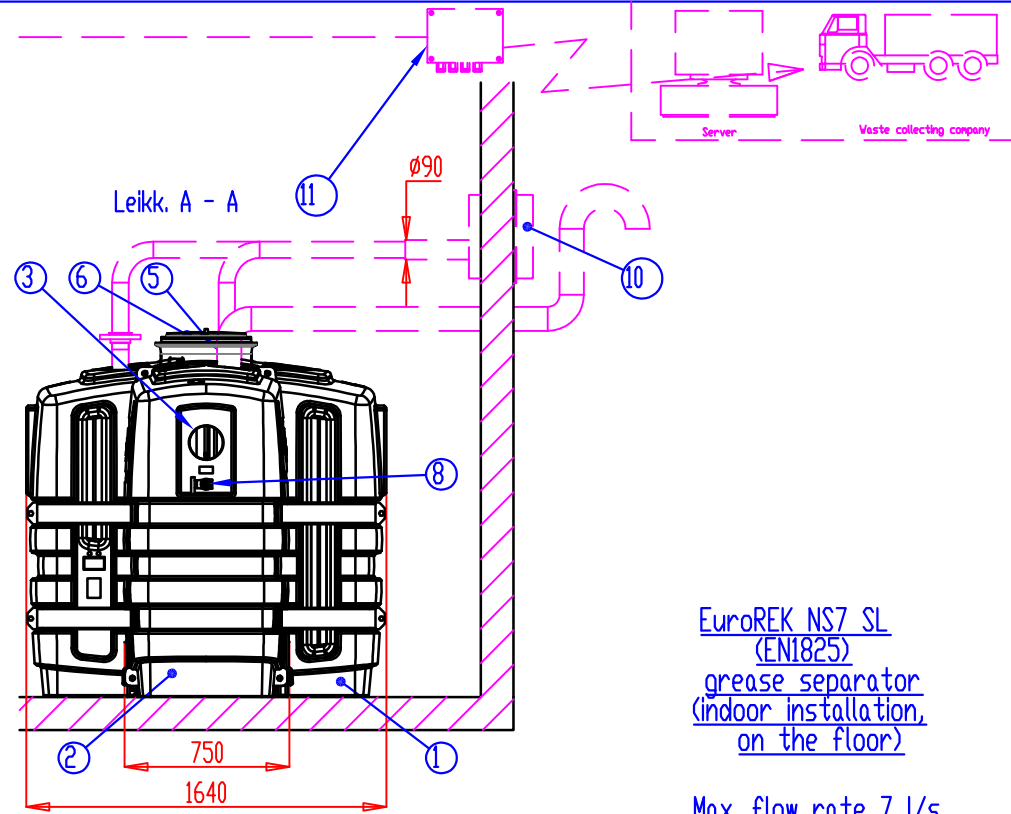

EuroREK NS7 SL
(EN1825)
grease separator
(indoor installation,
on the floor)

Max. flow rate 7 l/s

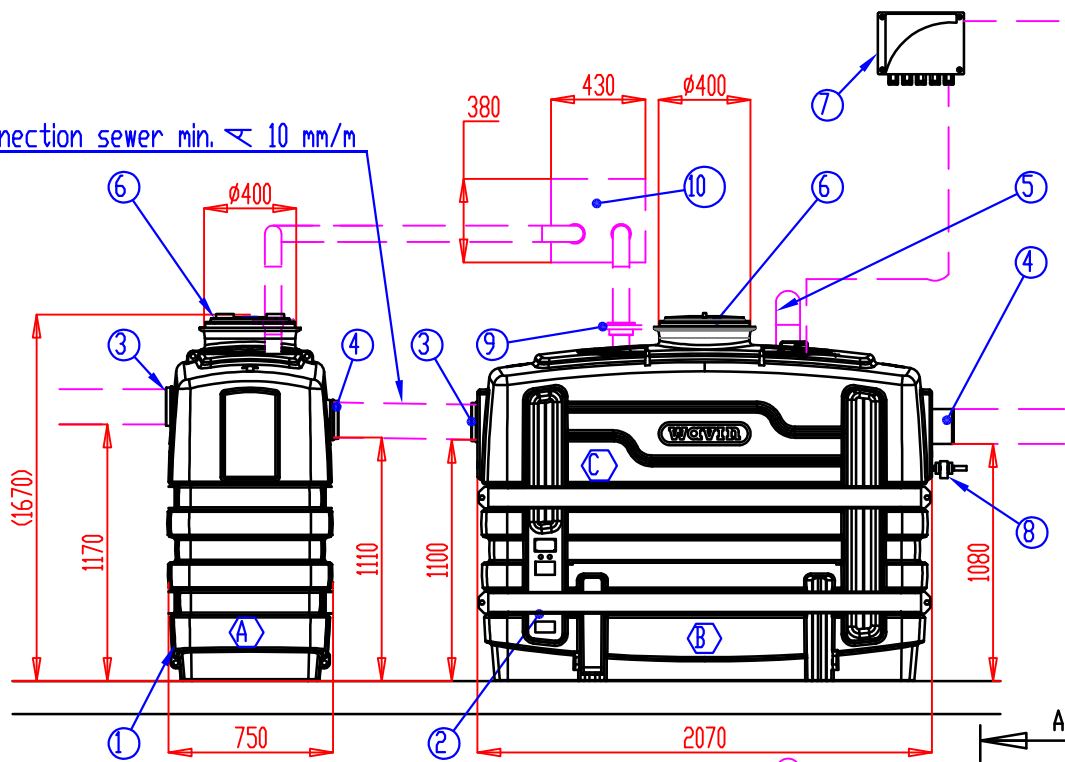
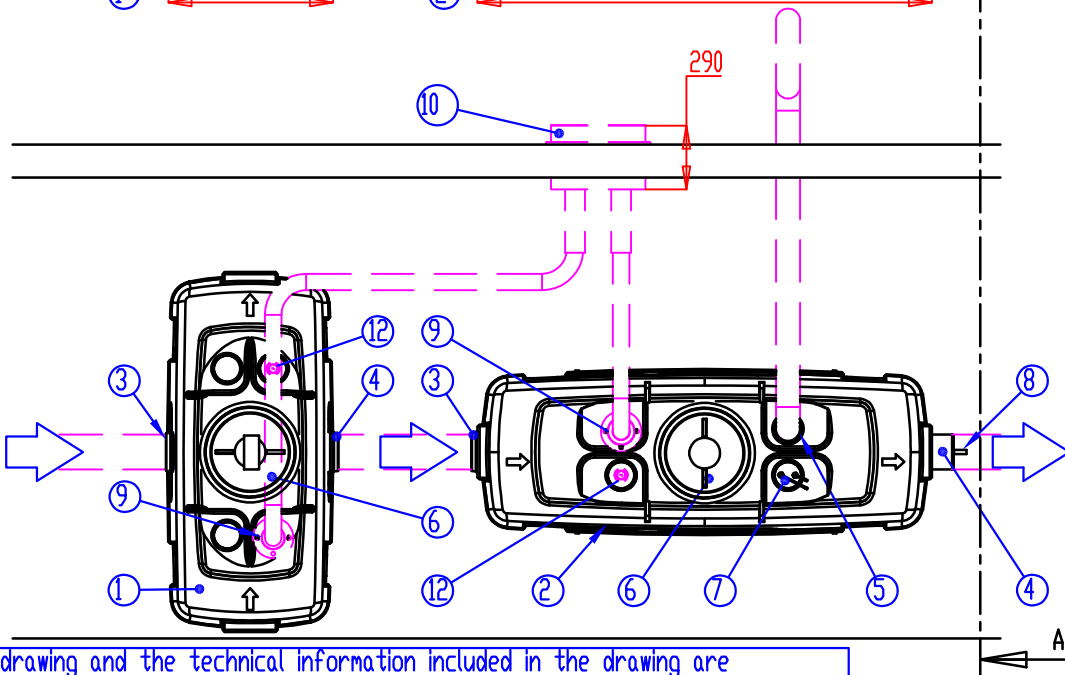

C	Grease storage capacity		280 l	
B	Effective capacity		1300 l	
A	Sludge capacity		900 l	
12	ACCESSORY: Washing nozzle (x)			(2)
11	ACCESSORY: Labcom data transfer unit (x)			(1)
10	ACCESSORY: Tuplalmubox quick coupling box (x)			(1)
9	ACCESSORY: Emptying pipe with flange (DN80) (x)			(2)
8	Sampling valve			1
7	Grease alarm unit			1
6	Lockable gas tight cover	PE-MD	D400	2
5	Ventilation outlet	PVC	D110	1
4	Outlet sewer	PVC/PE	D160	2
3	Inlet sewer	PVC	D160	2
2	Tank (pH3-10/Heat endurance max. 50°C), PE-MD, 2070x750x1670 mm			1
1	Tank (pH3-10/Heat endurance max. 50°C), PE-MD, 1640x750x1670 mm			1

Product			Drawing type	
EuroREK NS7 SL Grease separator (indoor)			CUSTOMER DRAWING	
Design by	Approved by	Drawing no	Date	Scale (A4)
HT/TL	HT 11.07.2016	32HB04ce	08.07.2016	1:35

This drawing and the technical information included in the drawing are property of Wavin-Labko Ltd. Authorities' regulations must be known before providing the product. Products must be installed according to installation instructions.



WAVIN
Labko

WAVIN-LABKO Oy
Visiokatu 1
FIN-33720 Tampere
FINLAND
puh. +358 020 1285 200
fax. +358 0201285 280

Construction site: