

Wavin Save Road Gullies

# rainwater drainage

from streets  
and roads



CONNECT TO BETTER



# Smart alternative to traditional road gullies

**Wavin Save Road Gullies have a unique sump made of PP and a full cast iron road gully cover. The road gullies comprise two parts. The sumps and road gully covers comply with ARBO (Dutch health & safety) regulations. The road gully covers are supplied standardly with a lock to prevent vandalism and for general safety. A wide range of road gully covers is available for different applications and surfaces. The sump has been designed to retain as much dirt as possible while allowing the rainwater to flow through as normal, so there is no water or dirt on the road! The Wavin Save Road Gullies are certified by KOMO and the road gully covers comply with the new European standard: NEN-EN 124 class B.**



## How road gullies function

Road gullies are used to collect rainwater that falls on impermeable surfaces and transport it to the drainage system or infiltration facility. To make this possible, the surface has a small slope in the direction of the road gully.

In order to reduce the costs for cleaning the main drainage system, the road gullies also prevent that street dirt enters the system. The number of square metres of closed surface per road gully depends on the nature of the surface and the slope and the rain intensity. For a car park with an asphalt surface, a good slope and an inflow to traditional gullies, 400 square meters per road gully is feasible. For open surfaces, 300 square meters per traditional road gully is the maximum that can be achieved.

The drainage capacity of Wavin Save road gullies is extremely high. Assuming rain showers of 60 l/s/ha, the quantity of rainwater that falls on 400 to 800 square meters of closed surface can be easily handled by a single road gully.

In practice, the distance between the road gullies on roads is 20 to 25 meters. This means that a road gully can handle 100 to 200 square meters of road surface. On bends and at junctions, the road gullies must be closer together to facilitate good water removal. The same is applicable for roads with higher gradients.

## Separating road rainwater with Wavin Save Road Gullies

Separating rainwater from the sewage system is a topical issue in the world of drainage. Contamination of the runoff rainwater reduces the efficiency of infiltration facilities.

Wavin Save Road Gullies offer innovative solutions for these problems. The new road gullies have a very large sand trap of 45 liters combined with a low height of 53 to 73 cm (road) or 83 cm (pavement). The road gullies can be supplied with an extra, removable dirt grille which optimally traps any dirt yet allows water to flow through.

Save road gullies can also be supplied with an air-releaser which can be used with QuickStream systems, etc.



# Advantages and features of Wavin Save Road Gullies

## Design

- ⦿ Robust
- ⦿ Extra-large sand trap of 45 liters
- ⦿ Low total height
- ⦿ Flat square underside
- ⦿ Short road gully with 25 liter sand trap
- ⦿ Removable dirt grille
- ⦿ Air-trap shut-off valve easily accessible to enable flushing of the drain pipe
- ⦿ Road gully covers are fitted as standard with a lock
- ⦿ Road gully covers comply with the new European standard: NEN-EN 124

## Materials

- ⦿ The sump is made of PP
- ⦿ This material is resistant to impacts, even at low temperatures
- ⦿ Sumps and covers are both light weight
- ⦿ The road gully as a whole complies with a class B (12.5 tonnes) traffic load
- ⦿ Cover is completely in cast iron

## Product range

- ⦿ Various road gully covers fit on the standard sump
- ⦿ 8 different covers for different bricks
- ⦿ Frame sizes 30, 50 and 70 mm
- ⦿ Air release gully also available
- ⦿ 1 key for all locks

## Service life

- ⦿ The high chemical resistance of plastic guarantees a long service life
- ⦿ The covers have a durable coating
- ⦿ Easy cleaning, flushing and inspection from ground level

## Dirt trap

- ⦿ Better trapping of dirt due to the larger distance between the settled dirt, floating dirt and gully connection



- 1) Standard sump (45 l.)
- 2) Low sump (25 l.)
- 3) Road gully (pavement) cover
- 4) Rijkswaterstaat (Department of Public Works) road gully cover
- 5) Road gully (pavement) cover with propeller motif
- 6) Road gully cover with propeller motif
- 7) Closed road gully cover
- 8) Road gully cover
- 9) Combi road gully cover
- 10) Road gully cover 5/20
- 11) Dirt grille
- 12) Air-trap shut-off valve
- 13) Frames
- 14) Key for locking

Easy to install, low maintenance, easy to manage

Installation



Easy positioning due to the flat, square underside.

The connection on the spigot can be made at various angles.

The Wavin Save Road Gully is easy to compact.

Short Save road gully with 25 liter sand trap; ideal where there are multiple cables and pipes. Less digging necessary.

Maintenance and management

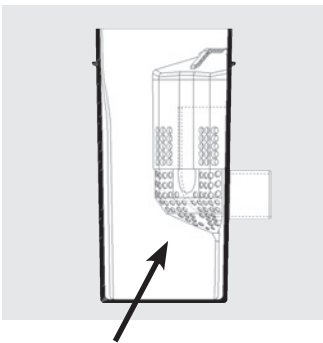

Position of the extra dirt grille.

Cleaning the road gully.

Flushing the road gully connection.

Video inspection of the road gully connection.

The frequency of cleaning the drainage system can be reduced by employing the new generation of road gullies rather than traditional road gullies. Wavin Save Road Gullies can be fitted with an extra dirt grille, considerably increasing the percentage of dirt that is trapped.

The dirt grille does not hinder cleaning. The sump is made completely of recycled, impact-resistant plastic.

Frames of various heights are available.

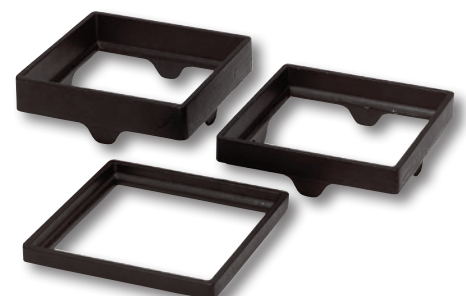

# Product range

## Road gully covers - Sumps - Frames - Dirt grilles

### Road gully

Type: SK  
Weight: 19,7 kg



### Sump

Weight: 11 kg  
Height: 70 cm  
Sand trap: 45 litres

### Road gully

with propeller motif  
Type: SK propeller  
Weight: 20,9 kg



### Low sump

Weight: 9,4 kg  
Height: 56,5 cm  
Zandvang: 25 litres

### Road gully

with closed grille  
Type: SK closed  
Weight: 20,5 kg



### Road gully (pavement)

Type: TK  
Weight: 35,8 kg



### 5/20 road gully cover

Type: 5/20  
Weight: 33,9 kg

### Road gully (pavement)

with propeller motif  
Type: TK waaier  
Weight: 35,8 kg

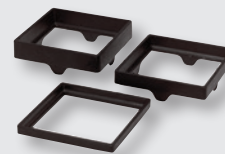

### Frames

Type: 3, 5 and 7 cm  
Weight: 3 cm = 5,3 kg  
5 cm = 8,1 kg  
7 cm = 11 kg

### Rijkswaterstaat (Department of Public Works) road gully

Type: RWS  
Weight: 35,8 kg

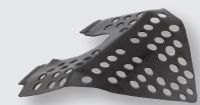

### Dirt grille

### Combi road gully

Type: Combi  
Weight: 30,3 kg

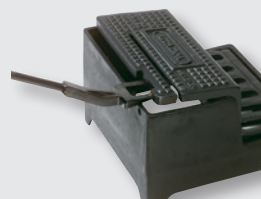

### Lock

All road gully covers are fitted as standard with a lock

# Dimensions

**Road gully**

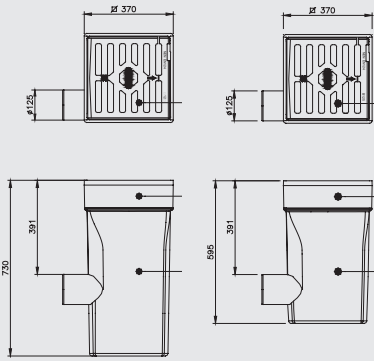

**Road gully propeller**

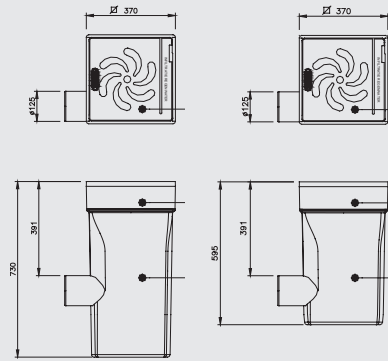

**Road gully closed**

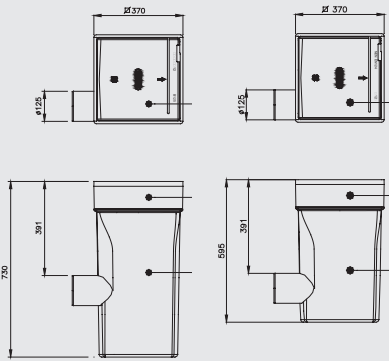

**Road gully (pavement)**

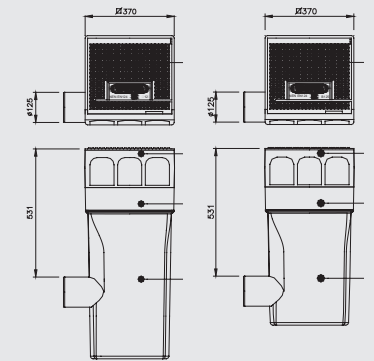

**Road gully (pavement) propeller**

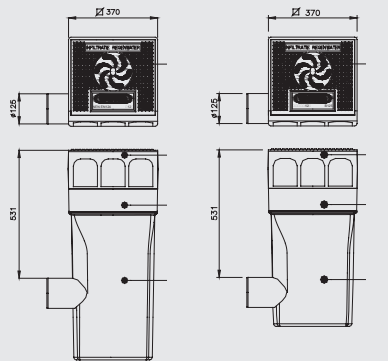

**Rijkswaterstaat  
(Department of Public  
Works) road gully**

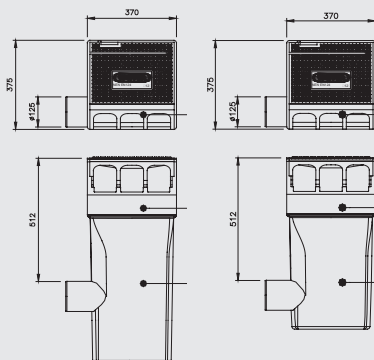

**Combi road gully**

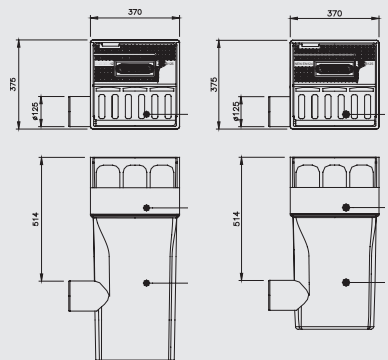

**5/20**

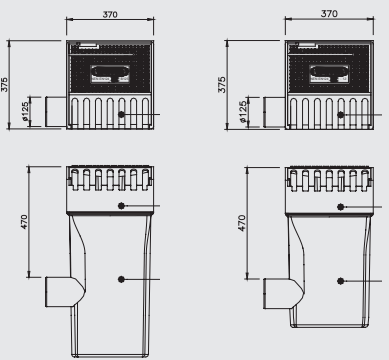

The range of road gully covers is regularly extended. For the current range and product specifications, please contact our sales department.

Discover our broad portfolio at  
**[www.wavinoverseas.com](http://www.wavinoverseas.com)**  
**[www.wavin.ae](http://www.wavin.ae)**  
**[www.wavin.asia](http://www.wavin.asia)**

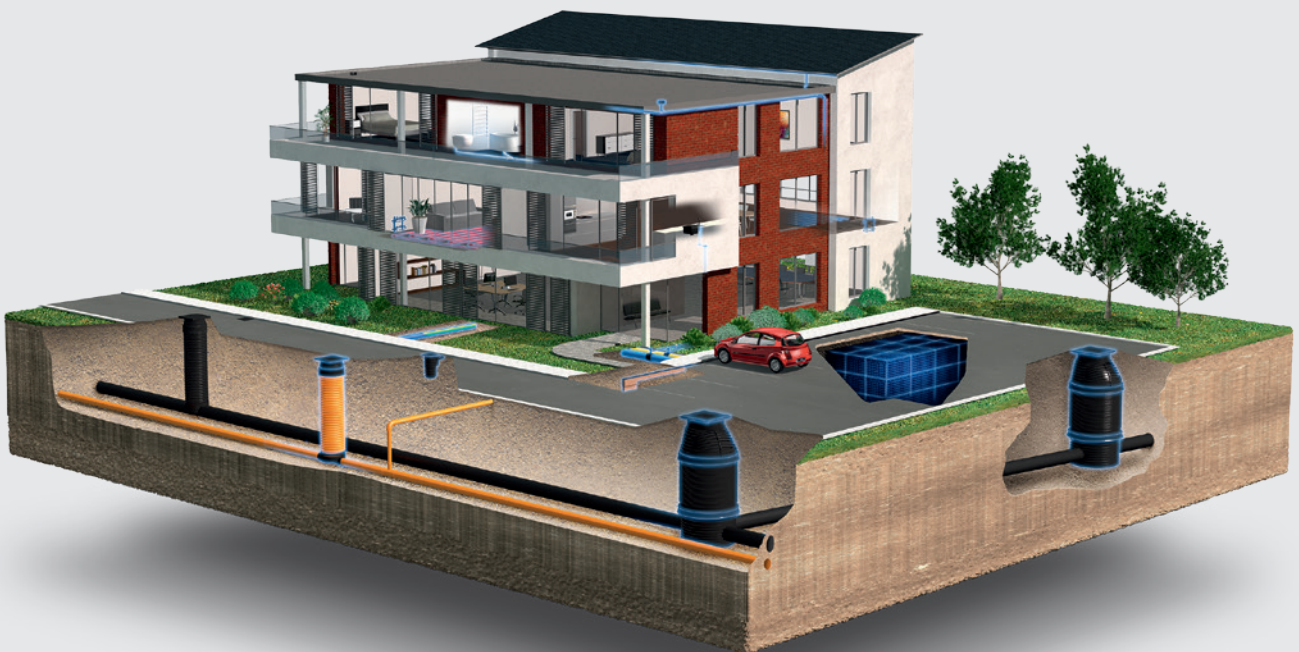

**Water management | Heating and cooling | Water and gas distribution**  
**Waste water drainage | Cable ducting**

**Connect to better at:**

- ⦿ [www.wavinoverseas.com](http://www.wavinoverseas.com) or
- ⦿ [www.wavin.ae](http://www.wavin.ae) for Middle East & North Africa
- ⦿ [www.wavin.asia](http://www.wavin.asia) for Asia Pacific

Wavin operates a programme of continuous product development, and therefore reserves the right to modify or amend the specification of their products without notice. All information in this publication is given in good faith, and believed to be correct at the time of going to press. However, no responsibility can be accepted for any errors, omissions or incorrect assumptions. Users should satisfy themselves that products are suitable for the purpose and application intended.



**CONNECT TO BETTER**