

PRODUCT AND INSTALLATION MANUAL

# Wavin AS+

## Acoustic Soil System



**wavin**

# Wavin AS+

## Low noise soil & waste drainage



## Contents

<b>1. Introduction</b>	<b>2-3</b>	<b>5. Installation and jointing</b>	<b>25-40</b>
1.1. System description	2	5.1. Connecting Wavin AS+ fittings and pipes	25-33
1.2. Field of application	2-3	5.2. General bracketing rules	34
1.3. Chemical resistance	3	5.2.1. Bracket Fixing Instructions	34
<b>2. Technical datasheet</b>	<b>4</b>	5.2.2. Bracket Arrangement	35
<b>3. Acoustics</b>	<b>5-14</b>	5.2.3. Max length of threaded rod	36-38
3.1. Sound insulation by Wavin AS+	5	5.2.4. Extended wall distance	38
3.2. Noise calculation software	5-6	5.3. Low noise installation – bracketing types	39
3.2.1. Wavin SoundCheck tool	7	5.3.1. Low noise bracketing – single bracket – 14 dB(A)	39
3.3. Sound-insulating performance	8	5.3.2. No-noise bracketing – Double bracket – lower than 10 dB(A)	40
3.4. About Sound	9	<b>6. Fire protection</b>	<b>41-46</b>
3.5. Noise	9-11	6.1. Fire behaviour classification	41
3.5.1. Sources of noise in buildings	11	6.2. Fire resistance classification	41
3.5.2. How noise is measured	11	6.3. Wavin fire protection concept	42
3.6. Acoustic requirements	12	6.4. Assembly instructions	42-46
3.7. Acoustic design	13	<b>7. Packing, transport &amp; storage</b>	<b>47</b>
3.7.1. Advantageous layout	13	<b>8. Wavin AS+ product range</b>	<b>48-57</b>
3.7.2. Acoustic plumbing design	14	<b>Annex I: Chemical resistance list</b>	<b>58-60</b>
<b>4. Design of the waste water system</b>	<b>15-24</b>	<b>Annex II: Specification clauses</b>	<b>61</b>
4.1. Installation and layout principles for waste water drainage systems	15		
4.2. List of definitions according to BS EN 12056	16-17		
4.3. Functional requirements	18-24		

# Wavin AS+

## 1. Introduction

### 1.1. System description

With regards to noise, Wavin is one of the pioneers. More than 30 years ago Wavin introduced the world's first plastic low noise Soil & Waste system.

After serving its purpose for more than 30 years, Wavin is introducing the successor of Wavin AS and is setting a new standard for low noise Soil & Waste solutions.

Wavin AS+ is the new best in class plastic sound-insulating Soil & Waste piping system, suitable for drainage of hot and cold waste water and in accordance with all requirements for non-pressurized waste water piping as laid down in BS EN 12056 and DIN 1986-100.

Wavin AS+ reduces the noise level of the Soil & Waste system better than any other plastic pipe system.

Due to the unique material composition for improved noise performance, premium reduction of unwanted sound emissions by the drainage system inside the building is assured. Optimal sound reduction is guaranteed due to high density of material.

Wavin AS+ is a mineral reinforced polypropylene (PP) low noise soil and waste solution.

Wavin AS+ is available in sizes ranging from DN50, DN100, DN150 & DN200.

Like all plastics, Wavin AS+ is durable, corrosion-resistant and able to withstand the chemical attack of all kinds of aggressive waste waters.

The new Wavin AS+ has been designed to meet the needs of engineers and installers. On top of 30 years of experience, we spent over a hundred thousand hours on noise level testing, explored new materials and invested heavily in developing a seal with integrated lubricant. This is why we can confidently say that the ultimate noise reduction and super easy installation delivered by the new Wavin AS+ is no coincidence.

Wavin AS+ includes unique product features that are contributing to the ease and safety of an installation:

- ④ New patented blue seal with integrated lubricant
- ④ Sculptured spigot reduces push-in force with 50% compared to Wavin AS
- ④ Blue seal's shape guarantees leak-free, failure-proof installation
- ④ Unique material composition delivers perfect sound absorption
- ④ Angular rotation guidance to align and rotate fittings in the right direction
- ④ Insertion depth check on fittings to make a secure and safe connection
- ④ Better handling during installation due to the grip features
- ④ Compact design perfect for small and narrow spaces

### Sealing

The elastomeric seal is made from EPDM in conformity with EN 681-1.

### Approvals and testing

Wavin AS+ pipes and fittings are continually subject to strict quality controls according to DiBt in Berlin. Wavin AS+ pipes & fittings have been awarded DiBt buildings' inspection approval (DiBt Z-42.1-569) and are, therefore, deemed suitable for use as above ground pipework. Germany: DiBt, Z.-42.1-569

### 1.2. Field of application

#### Areas of application

Wavin AS+ is resistant to hot water and fulfils or exceeds all the requirements of BS EN 12056 and the associated norms given in DIN 1986-100, i.e. short-term exposure to temperatures of 95°C and long-term exposure to temperatures of 90°C.

The chemical resistance of Wavin AS+ makes it suitable for transporting waste water in the range pH 2 - 12.

Wavin AS+ is suitable for above ground drainage.

The outstanding acoustic performance of WAVIN AS+ makes it ideal for wherever DIN 4109-compliant sound insulation might be required, such as in hospitals, hotels, nursing homes, office buildings, or single/multi-occupancy residential properties.

#### Noise pollution affects both health and behaviour.

Exposure to noise can affect both health and behaviour. Unwanted sound (noise) can damage physiological health. It can cause hypertension, high stress levels, tinnitus, hearing loss, sleep disturbances, and other harmful effects. It is for this reason that modern buildings are equipped with a range of sound-insulation measures designed to favour comfortable living, such as thick exterior walls and soundproofed windows. But we often forget that noise is not just external; it can also be generated from inside the building. Wavin wants to create better buildings. Wavin AS+ is a premium-quality, sound-insulating pipe system designed to minimise noise from plumbing systems and maximise living comfort.

### **Commercial kitchens and abattoirs**

Wavin AS+ is ideal draining fat-containing waste water from e.g. commercial kitchens and abattoirs. Long-term functional reliability and temperature resistance (continuous exposure up to 90°C / short-term up to 95°C in accordance with BS EN 12056 / DIN 1986-100) are fundamental requirements here. The smooth internal surface of the pipe prevents incrustations. When installing Wavin AS+ in commercial kitchen and abattoirs with high fat-containing waste water, the use of NBR sealing rings is advised. If fat-containing waste waters need to cover a long distance before reaching the grease-trap facilities, the premises have to be equipped with an auxiliary electric heating system designed to keep the waste water in a liquid state, while maintaining a temperature of no more than 70°C.

### **Photographic laboratories**

Wavin AS+ pipes and fittings – made of mineral-reinforced PP and supplied with factory-fitted sealing rings – are resistant to the developing and fixing media used in photographic laboratories over long-term exposures at 60°C. They are also approved for short-term temperature loads of up to 95°C. (Please refer to the Chemical Resistance List in the annex for further details).

It is recommended that piping is installed with sufficient fall to reduce the contact time between fluid and guiding surface to a minimum.

### **Dental practices**

Wavin AS+ can be used unreservedly in dental practices, provided the piping downstream of the dentist's chair is fitted with an integrated amalgam separator. Wavin AS+ (including the sealing rings) is resistant to dental amalgam. In addition, cleaning agents and disinfectants normally used in dental practices, if present in the usual concentrations, are harmless to the pipe system.

### **Food-processing and chemical industries**

Usage with waste water containing lactic acid from the food sector and chemical industry, Wavin AS+ pipes and fittings are resistant to media containing lactic acid (at concentrations up to 90%) at liquid temperatures up to 60°C. This also applies to the factory-fitted EPDM sealing ring that form part of the push-fit connecting system, especially as contact is marginal. It is recommended that piping is installed with sufficient fall to reduce contact time to a minimum.

### **1.3 Chemical resistance**

The data in the chemical resistance list is intended only as a guide for planning purposes and are not automatically applicable to all conditions of use. Considerable deviations can occur dependent on type of exposure and probable contamination of the chemical medium. Wavin cannot be held liable for any special, indirect or consequential damages irrespective of whether caused or allegedly caused by negligence. No warranty can be derived concerning the data mentioned.

For the complete chemical resistance list see Annex I (pages 58-60).

# Wavin AS+

## 2. Technical datasheet

Wavin AS+ is a mineral reinforced polypropylene (PP) low noise soil and waste solution. A unique material composition for improved noise performance. Optimal sound reduction is guaranteed due to high density of material. Optimized three layer pipe structure for low noise levels push fit connections with a pre-lubricated elastomer seal (EPDM) for quick, easy and reliable installation.

### Material

Polypropylene, mineral-reinforced.

### Physical properties

⊖ Density	~ 1,9 g/cm <sup>3</sup>
⊖ E-Modul	~ 1800 N/mm <sup>2</sup>
⊖ Linear coefficient of thermal expansion	~ 0,06 mm/mK
⊖ Reaction to fire	DIN 4102, B2 and BS EN 13501 D-S3, d0
⊖ Temperature	Short-time load by 95°C and 90°C long-term stress

### Colour

Light grey RAL7035

### Pipe data

DN	d <sup>1)</sup>	d <sub>i</sub> <sup>2)</sup>	s <sup>3)</sup>
50	50	44	3.0
100	110	99.4	5.3
150	160	148.8	5.6
200	200	188	6.0

1. Outer diameter in mm
2. Inner diameter in mm
3. Wall thickness in mm

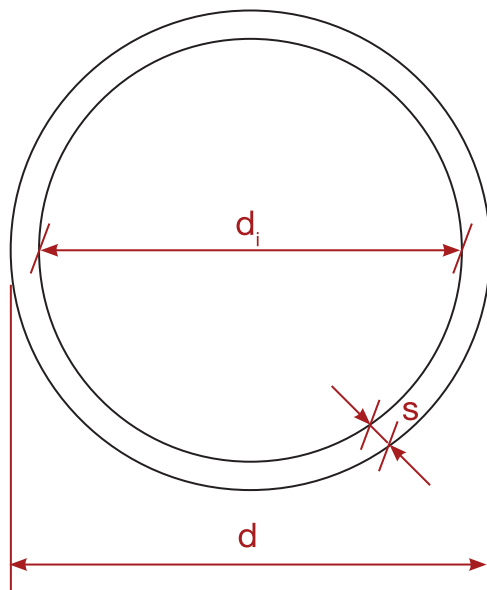

### Marking

Wavin AS+, nominal width, date, certification mark, material, fire class.

Example: Wavin AS+, DN100, date, Z.-42.1-569, mineral-reinforced PP Ü DIN 4102, B2.

# Wavin AS+

## 3. Acoustics

### 3.1. Sound insulation by Wavin AS+

The excellent sound protection properties of Wavin AS+ are primarily attributed to its thick-walled design as well as special molecular structure and the high density of  $\sim 1.9 \text{ g/cm}^3$  of the material. This property enables Wavin AS+ to absorb airborne sound as well as mechanical vibrations.



A contribution to sound protection is made by the special product design and system solutions.

- Swept branches for minimal flow disturbance in the down pipe
- Due to unique system bracket and high structure born sound prevention



Figure 1: Double branch.



Figure 2: Wavin system bracket.

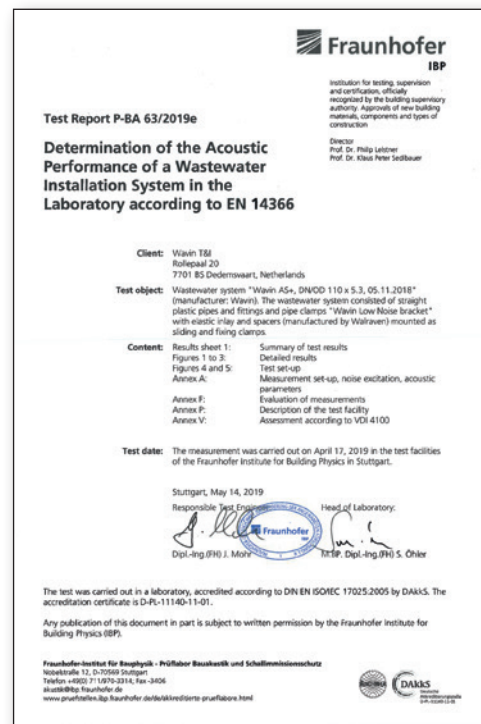

In studies conducted at the Fraunhofer Institut für Bauphysik (Fraunhofer Institute for Building Physics), Stuttgart, Wavin AS+ has proven its excellent sound absorption properties. The tests were performed in a laboratory accredited by the German Accreditation System for Testing (DAP, file no. PL-3743.26) according to standard EN ISO/IEC 17025.

The measurements in this test were performed following German standard DIN EN14366 and DIN 52219:1993-07; noise excitation by stationary water flow with 0.5 l/s, 1.0 l/s, 2.0 l/s., 3.0 l/s and 4.0 l/s.

### 3.2. Noise calculation software

Determination of the sound level as conducted by Fraunhofer Institut Bauphysik is in general useful to determine the noise level of a pipe system in a static situation. The test method is, however, based on a laboratory set up in which all building parameters are kept the same except for a change in water flow. As a result it is impossible to obtain by this test a realistic figure of the noise levels for the protect chambers of actual projects.

# Wavin AS+

## 3. Acoustics

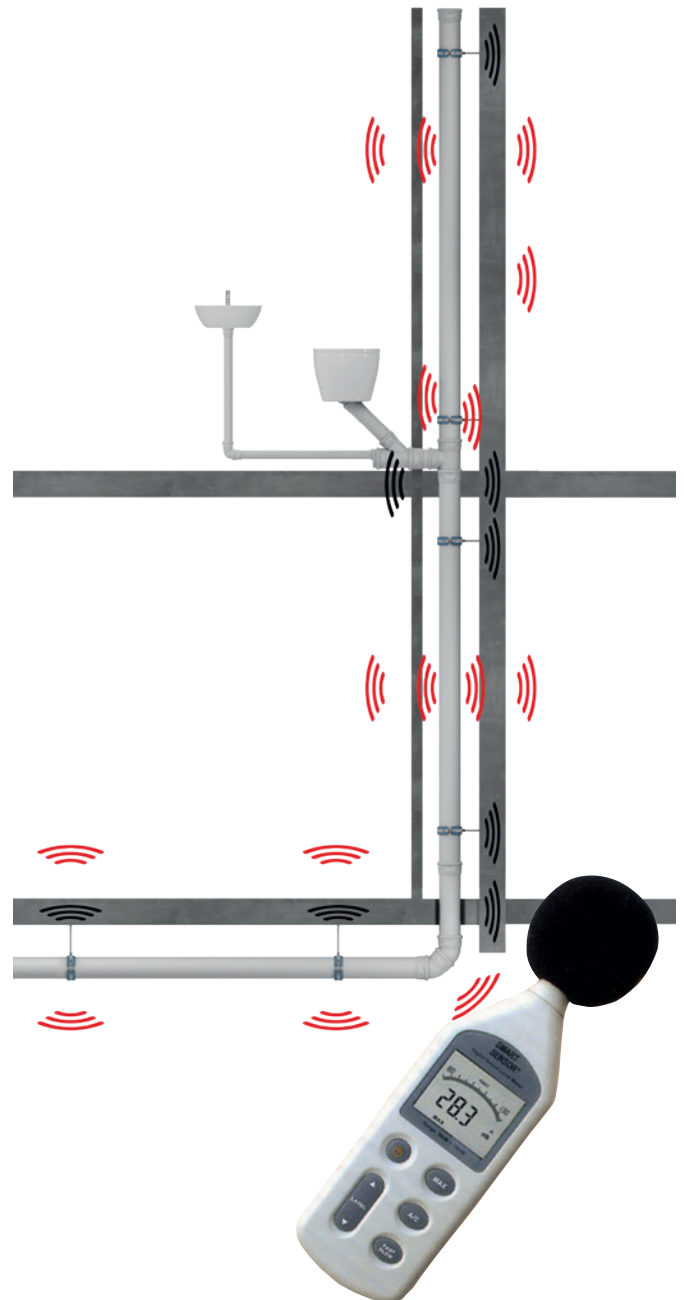
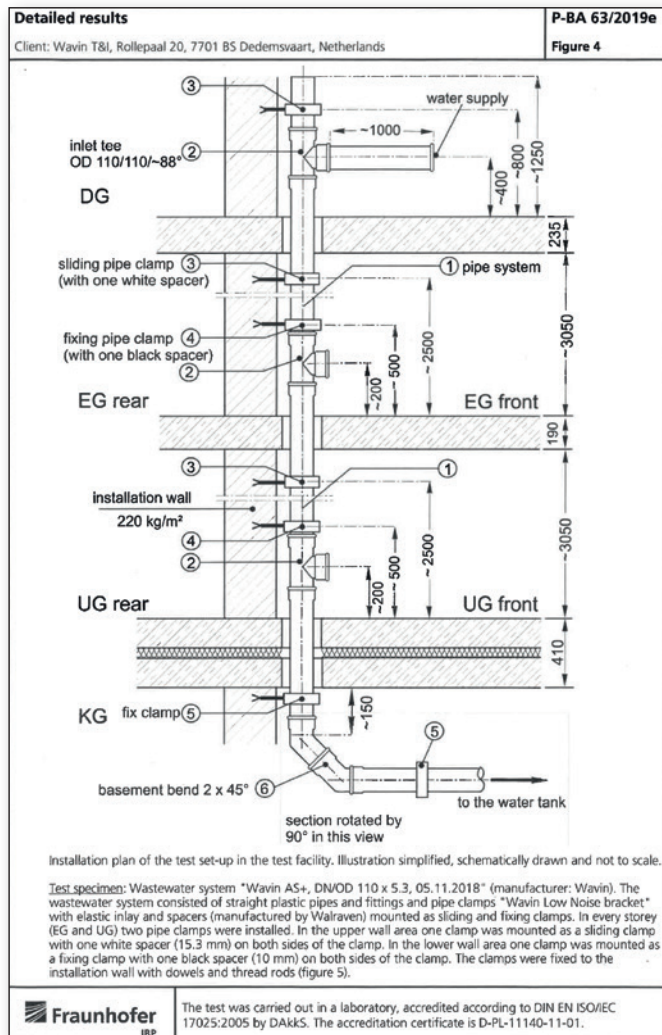

Figure 3: FRAUNHOFER Test set up for determination of the installation sound level in the laboratory.

To actually determine real noise emission of the pipe system into a room requires a more dynamic test set up in which at least the following parameters can be modified.

- ④ Pipe system characteristics
- ④ Building design
- ④ Shaft characteristics
- ④ Suspended ceiling criteria
- ④ Structural characteristics of the building
- ④ Flow parameters
- ④ Installation requirements
- ④ Insulation requirements

### 3.2.1. Wavin SoundCheck tool

#### Calculating system acoustic just got easier

With noise regulations continuously being updated, calculating noise levels to ensure your design meets requirements can be a complex exercise. Wavin's online SoundCheck Tool is designed to relieve some of that stress.

Unique to Wavin, the SoundCheck Tool simulates system acoustics in a final installation and calculates noise levels based on individual parameters. In just six clearly defined and intuitive steps, you can get the answers you need to see if your design meets regulations.

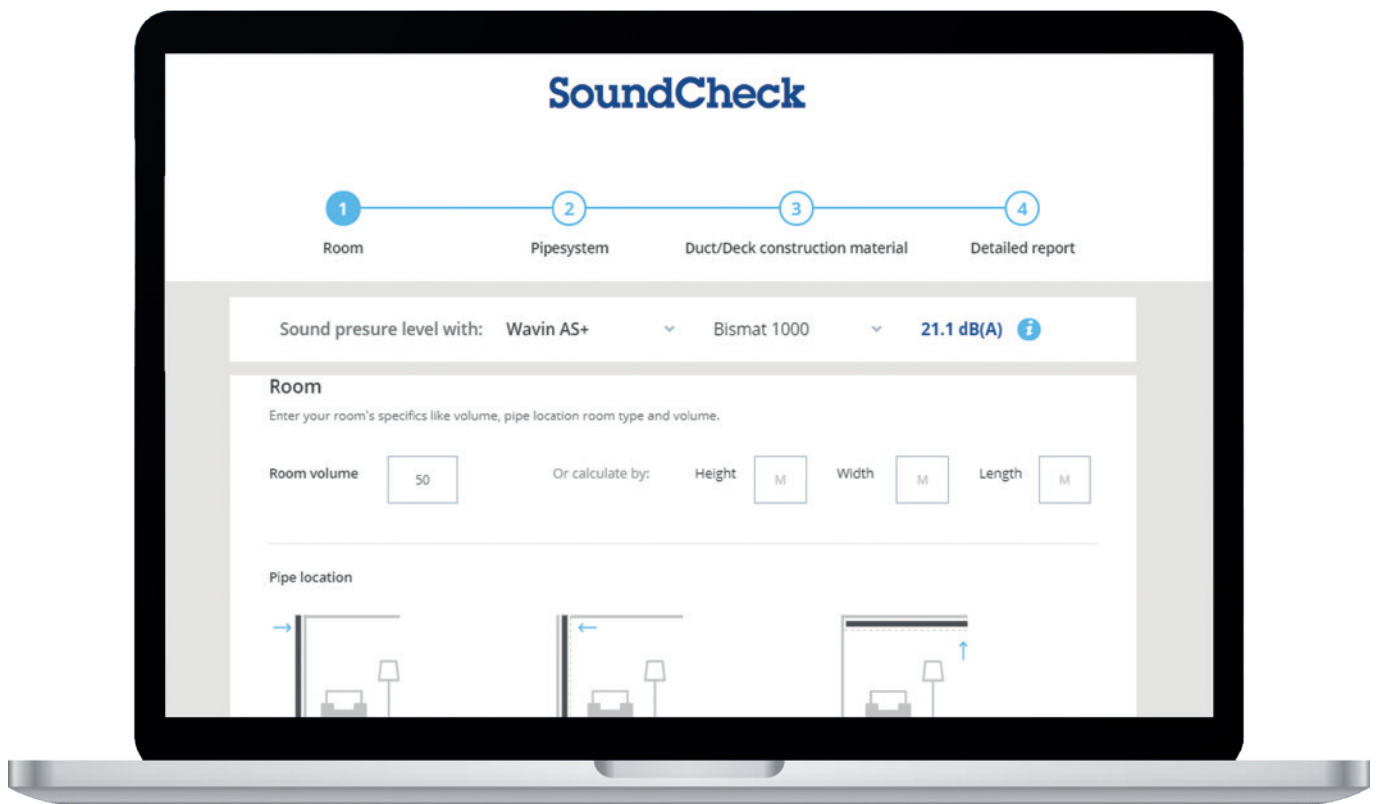



# Wavin AS+

## 3. Acoustics

### 3.3. Sound-insulating performance

The excellent sound protection properties of Wavin AS+ are primarily attributed to its thick-walled design as well as special molecular structure and the high density of  $\sim 1.9 \text{ g/cm}^3$  of the material used to make the pipes and fittings. This property enables Wavin AS+ to absorb airborne sound as well as structure borne sound.

Studies conducted at the Fraunhofer Institut für Bauphysik (Fraunhofer Institute for Building Physics), Stuttgart, on Wavin AS+ attest to its excellent sound absorption properties.

Wavin low noise bracket installation	Volumetric flow rate*		Meets standard
	2 l/s	4 l/s	
DIN 4109 (public minimum legal requirement) specification 30dB(A)	14 dB(A)	19 dB(A)	✓
VDI 4100 sound insulation level II/III specification 27/24 dB(A)	11 dB(A)	16 dB(A)	✓
Installation noise level in rear basement (P-BA 63/2019)			
Wavin no noise bracket installation	Volumetric flow rate		Meets standard
	2 l/s	4 l/s	
DIN 4109 (public minimum legal requirement) specification 30dB(A)	<10 dB(A)	13 dB(A)	✓
VDI 4100 sound insulation level II/III specification 27/24 dB(A)	<10 dB(A)	10 dB(A)	✓
Installation noise level in rear basement (P-BA 64/2019)			

\*Installation noise levels based on installation with Wavin system brackets.

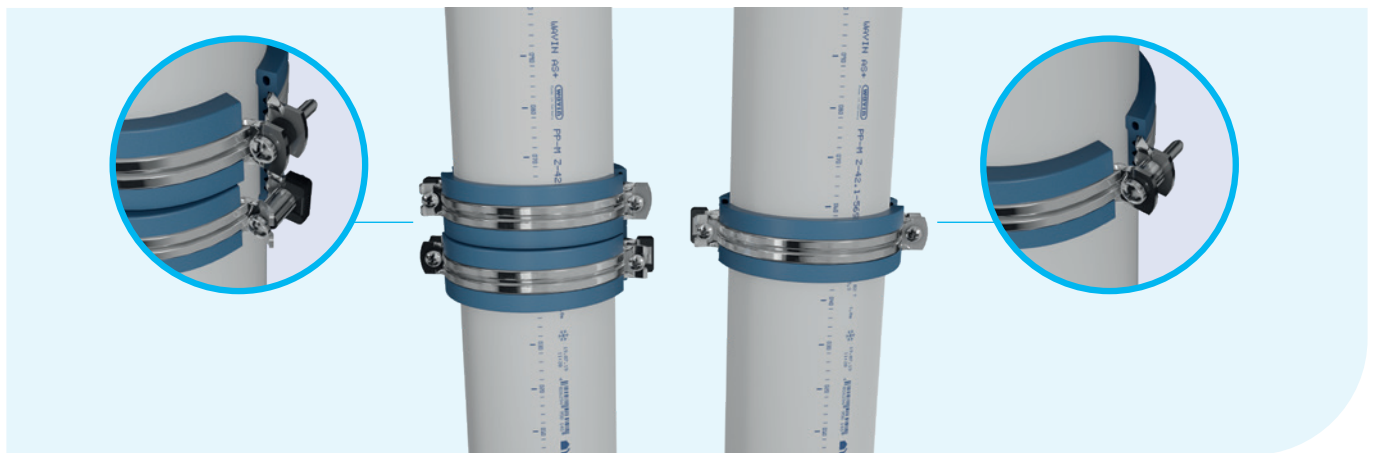

With no noise bracket arrangement  
 ⓘ <10 dB(A) according to 64/2019

With low noise bracket arrangement  
 ⓘ 14 dB(A) according to 63/2019

### 3.4. About Sound

Sound is a sensation felt, a perception of what takes place around us, caused by various compression waves which cross the eardrum and are captured and transformed by the brain; it is composed of different frequencies. The acuteness or intensity of the perception depends on the frequency and range.

Sound is a wave that is:

- ⦿ Elastic (it needs a medium to be propagated)
- ⦿ Longitudinal (perturbation takes place parallel to the direction of propagation)

To exist it requires:

- ⦿ A source (vibrating body)
- ⦿ An elastic propagation medium (air, water, etc.)

A sound is therefore a method of transmitting mechanical energy. To propagate, a sound needs a medium: any means, whether solid, liquid or gassy, like air, is able to transport sound, influencing its speed according to density.

Sound is propagated through the exchange of air-solid-air or solid-air vibrations (in the second case the solid is the source of the sound). With respect to soundproofing soil and waste systems, we need to think in two different directions: (1) the noise created in the pipes and transmitted by them and (2) noise which is transmitted by the walls or surrounding media.

Sound is measured with a phonometer, an instrument which filters noise and measures intensity at its different frequencies. It is expressed in decibels.

The decibel is the logarithm of the ratio between the measured sound pressure and a reference sound pressure, multiplied by ten.

$$dB = 10 \log (P/Pa)$$

We need to remember that sound is an energy (just think of when you stand in front of the stereo speakers and you can "feel" the basses) but what we perceive is a processed sensation.

The human ear is sensitive to pressure in a NON LINEAR manner; therefore twice the pressure does not correspond to twice the sensation.

The doubling of acoustic power corresponds to an increase of 3 dB.

Every 10 dB increase is perceived by the human ear as twice as loud (10 cars are perceived as twice as loud as 1 car).

$$60 \text{ dB} + 50 \text{ dB} + 40 \text{ dB} = 60.5 \text{ dB} \longrightarrow$$

The highest dB is in a sum the most important

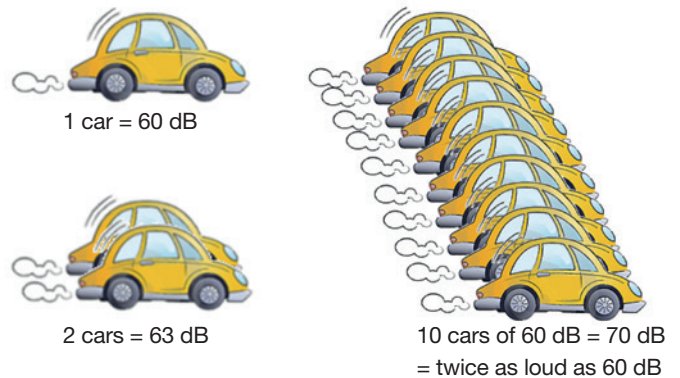

Sound intensity follows an inverse square law with distance from the source; doubling the distance from a noise source reduces its intensity by a factor of four, or 6 dB.

### 3.5. Noise

Noise can be described as unwanted sound. In relation to sound, noise is not necessarily random.

Acoustic noise can be anything from quiet but annoying to loud and harmful causing permanent irreversible hearing damage.



# Wavin AS+

## 3. Acoustics

Based on the World Health Organization (WHO) guidelines, European countries have maximized the noise level (in houses, apartments, hospitals, elderly homes, hotels, etc.) during the night to:

**$L_A \text{ max night} = 30 \text{ to } 35 \text{ dB(A)}$ .**

Community noise (also called environmental noise, residential noise or domestic noise) is defined as noise emitted from all sources except noise at the industrial workplace.

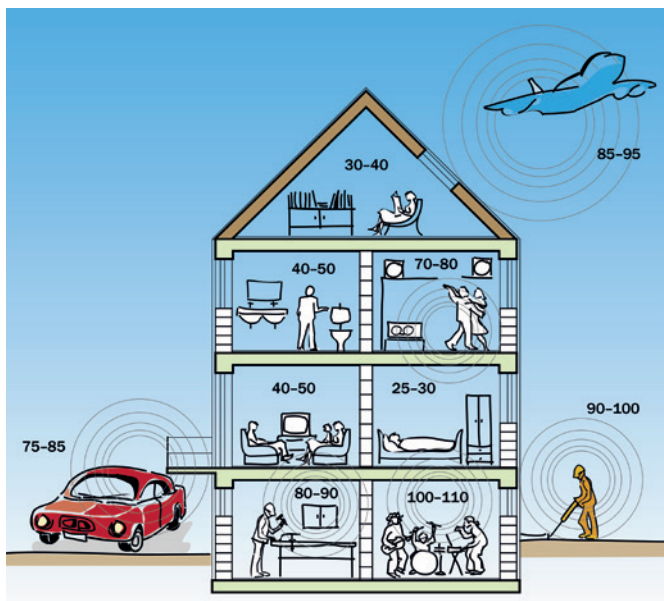

Figure 4: Example of community noise.

In the European Union about 40% of the population is exposed to road traffic noise with an equivalent sound pressure level exceeding 55 dB(A) daytime, and 20% are exposed to levels exceeding 65 dB(A). When all transportation noise is considered, more than half of all European Union citizens is estimated to live in zones that do not ensure acoustical comfort to residents. At night, more than 30% are exposed to equivalent sound pressure levels exceeding 55 dB(A), which are disturbing to sleep. Noise pollution is also severe in cities of developing countries.

In contrast to many other environmental problems, noise pollution continues to grow and it is accompanied by an increasing number of complaints from people exposed to the noise.

The growth in noise pollution is unsustainable because it involves direct, as well as cumulative, adverse health effects.

For instance sleep disturbance: measurable effects of noise on sleep begin at sound levels of about 30 dB. However, the more intense the background noise, the more disturbing is its effect on sleep. Sensitive groups mainly include the elderly, shift workers, people with physical or mental disorders and other individuals who have difficulty sleeping.

Table 1 presents the WHO guideline values arranged according to specific environments and critical health effects. The guideline values consider all identified adverse health effects for the specific environment. An adverse effect of noise refers to any temporary or long-term impairment of physical, psychological or social functioning that is associated with noise exposure. Specific noise limits have been set for each health effect, using the lowest noise level that produces an adverse health effect (i.e. the critical health effect).

Table 1: Guideline values for community noise in specific environments (Source World Health Organization).

Specific environment	Critical health effect(s)	$L_{Aeq}$ [dB(A)]	Time base [hours]	$L_{Amax}$ fast [dB]
Outdoor living area	Serious annoyance, daytime and evening	55	16	-
	Moderate annoyance, daytime and evening	50	16	-
Dwelling, indoors	Speech intelligibility & moderate annoyance, daytime & evening	35	16	-
Inside bedrooms	Sleep disturbance, night-time	30	8	45
Outside bedrooms	Sleep disturbance, window open (outdoor values)	45	8	60
School class rooms & pre-schools, indoors	Speech intelligibility, disturbance of information extraction, message communication	35	during class	-
Pre-school bedrooms, indoor	Sleep disturbance	30	sleeping-time	45
School, playground outdoor	Annoyance (external source)	55	during play	-
Hospital, ward rooms, indoors	Sleep disturbance, night-time	30	8	40
	Sleep disturbance, daytime and evenings	30	16	-
Hospitals, treatment rooms, indoors	Interference with rest and recovery	#1		
Industrial, commercial shopping and traffic areas, indoors and outdoors	Hearing impairment	70	24	110
Ceremonies, festivals and entertainment events	Hearing impairment (patrons:<5 times/year)	100	4	110
Public addresses, indoors and outdoors	Hearing impairment	85	1	110
Music and other sounds through headphones/earphones	Hearing impairment (free-field value)	85 #4	1	110
Impulse sounds from toys, fireworks and firearms	Hearing impairment (adults)	-	-	140 #2
	Hearing impairment (children)	-	-	120 #2
Outdoors in parkland and conservations areas	Disruption of tranquillity	#3		

#1: As low as possible.

#2: Peak sound pressure (not LAF, max) measured 100mm from the ear.

#3: Existing quiet outdoor areas should be preserved and the ratio of intruding noise to natural background sound should be kept low.

#4: Under headphones, adapted to free-field values.

It is not enough to characterize the noise environment in terms of noise measures or indices based only on energy summation (e.g., LAeq), because different critical health effects require different descriptions.

It is equally important to display the maximum values of the noise fluctuations, preferably combined with a measure of the number of noise events. A separate characterization of nighttime noise exposures is also necessary.

For indoor environments, reverberation time is also an important factor for things such as speech intelligibility. If the noise includes a large proportion of low-frequency components, still lower guideline values should be applied.

Supplementary to the guideline values given in Table 1, precautions should be taken for vulnerable groups and for noise of certain character (e.g. low-frequency components, low background noise).

### 3.5.1. Sources of noise in buildings

The noise generated by the building and its utilities may be classified as follows:

- ④ Noise due to filling operations
- ④ Noise generated by control equipment
- ④ Intake noise
- ④ Discharge noise
- ④ Noise due to impact or shock

Noise is generated by moving parts or by flowing media. Waste water discharge pipes are prone to vibration, particularly where water flows through downpipes, or is forced to change direction in joints and elbows (noise due to impact or shock). Experience shows that the greatest problems are typically caused by the transmission of structural noise, particularly in the area of pipe clamps and brackets or where pipe-work is run through walls or ceilings.

The noise created from waste systems obviously depends greatly on the vertical piping. Here the falling water clashes against the wall of the pipes and fittings. The generated noise is transmitted directly to the pipes and indirectly through the ducts and installation walls. Therefore, the thickness and mass of the solid materials are of great importance, just like the fixing brackets and other elements which connect pipes to their supports.

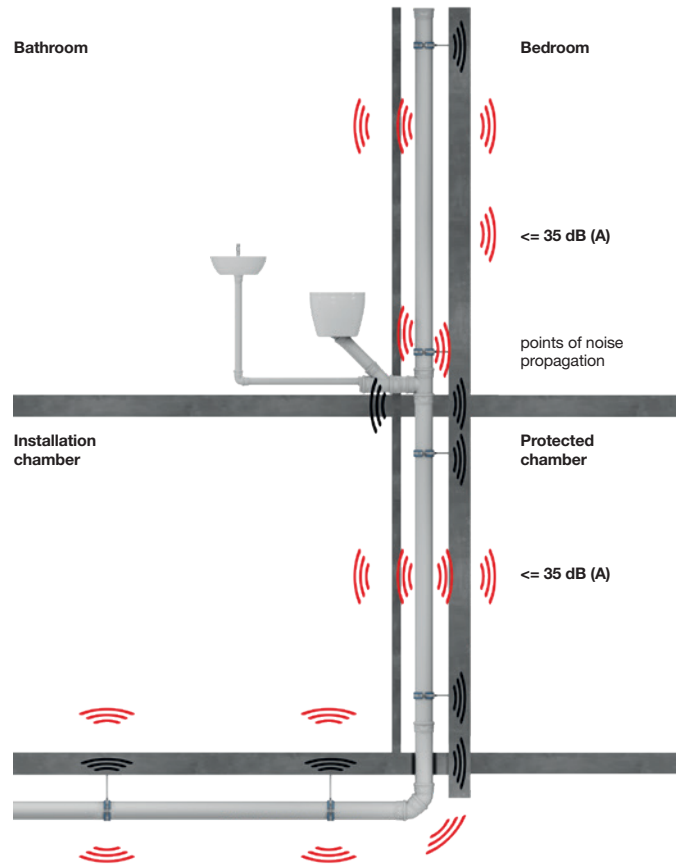

Figure 5: Example of noise propagation during drainage.

### 3.5.2. How noise is measured

If we consider the “installation chamber” to be the room in which the pipes are installed (generally the bathroom), the room next door divided by the installation wall is called the “protected chamber”. The noises emitted are measured in the protected chamber according to EN 14366.

# Wavin AS+

## 3. Acoustics

### 3.6. Acoustic requirements

Local ruling increasingly describe the maximum acceptable sound level inside the living area of a building. Subsequently such noise limitation will then have to be established in contracts between the contractor and the awarding authority.

The following technical regulations contain relevant advice and suggestions, which require a contractual agreement to become binding.

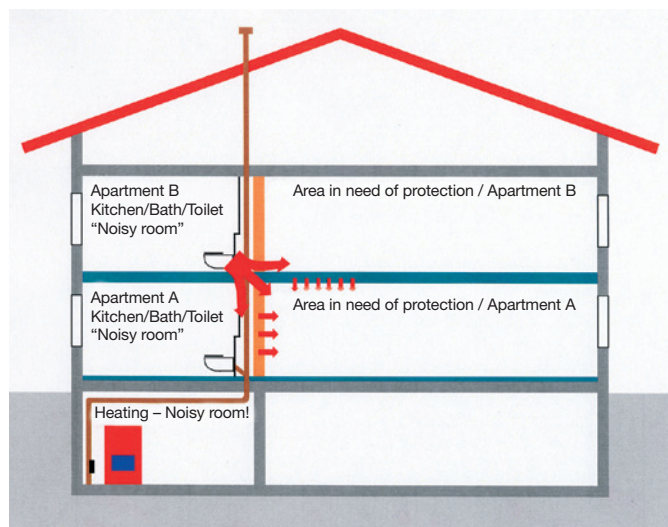

- Shared floor/ceiling in residential apartment building > 410 kg/sq.m
- Single-skin installation wall within domestic living quarters > 220 kg/sq.m

Figure 6: Example of areas requiring protection.

#### DIN4109-5

This supplement contains instructions relating to noise levels that lie 5 dB (A) below the values given in DIN 4109-1:20/6-07.

In accordance with DIN 4109-5, increased levels of sound insulation can be arranged, by agreement, to a maximum of 25 dB (A) in other areas requiring noise protection.

#### VDI 4100

In addition to the requirements of DIN 4109, which was adopted as Noise Protection Level I (NPL I), this guideline contains characteristic values for two additional noise protection levels – NPL II and NPL III.

These two additional noise protection levels specify the arrangements for increased sound insulation.

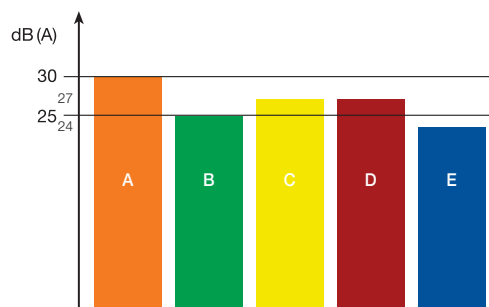

- A: DIN 4109 (minimum legal requirements)
- B: DIN4109-5 Living rooms and bedrooms in apartment buildings
- C: VDIN 4109-5 Living rooms and bedrooms in single-family houses
- D: DI4100 Noise Protection Level II
- E: VDI4100 Noise Protection Level III

Figure 7: Overview Noise Protection Standards and Guidelines.

### 3.7. Acoustic design

#### 3.7.1. Advantageous layout

An important factor for the assurance of acoustic insulation is the design and implementation of an acoustically advantageous layout.

The following measures have proven to be of significant influence to the level of noise generated from the soil system inside the building:

- ④ Noise-sensitive areas should be kept away, as far as possible, from sources of noise
- ④ Non-sensitive areas should, wherever possible, be used as “buffer zones”
- ④ Noise-sensitive areas should not be positioned in the direct vicinity of bathrooms, toilets or stairwells
- ④ Potential sources of noise should be “bundled together” in the same area

The comparison between the two examples of layout shown above demonstrates how the acoustically advantageous layout in the second example contributes to a clear reduction in the acoustic pressure of the systems in the room which demands acoustic insulation.

However, even using highly efficient low-noise waste systems like Wavin AS+, one always has to seek for the best possible acoustic decoupling. This goes for the whole drainage system and its points of contact with the building (collars, crossings through walls and floors, plaster residues between the pipe and the building, etc...).

In designing piping, moreover, we need to avoid positioning waste pipes in the partition walls between apartments. Special noise-reduction measures also need to be adopted when fixing drain pipes to the partition walls between apartments. Protect the pipes from the propagation of intrinsic noise.

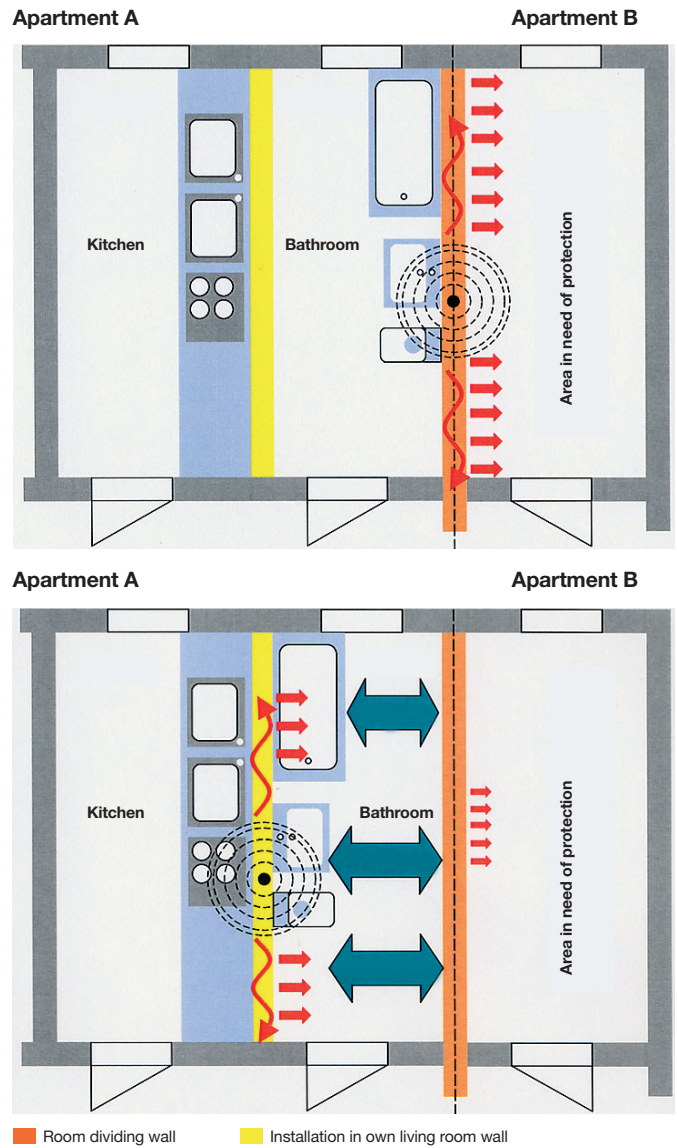

Figure 8: Examples of good acoustic practice in building design.

The comparison of the floor plans above demonstrates how good acoustic design in the lower building example can significantly reduce the noise levels to which areas requiring noise protection are exposed.

# Wavin AS+

## 3. Acoustics

### 3.7.2 Acoustic plumbing design

Wavin AS+ can significantly reduce noise levels when compared with other piping systems. However, when installing high performance sound-insulating waste water piping systems it is still necessary to consider how effectively the system can be sound-isolated. This applies to the waste water discharge system as a whole, including its points of contact with the building structure (pipe brackets and clamps, the running of pipework through walls and ceilings, mortar droppings between pipes and wall surfaces, etc.).

When planning pipe installation, waste water discharge pipes should not be allowed to run inside the walls separating living areas. The attachment of waste water discharge pipes to partition walls in living areas should only be carried out under application of special noise protection measures. DIN 4109 requires that single-skin walls to which, or in which, water installations or equipment (i.e. waste water pipes) are to be attached must have an area-related mass of at least 220 kg/ sq.m. Walls having an area-related mass of less than 220 kg/ sq.m may only be used where prior testing has demonstrated that the walls exhibit acceptable properties with respect to the transmission of noise.

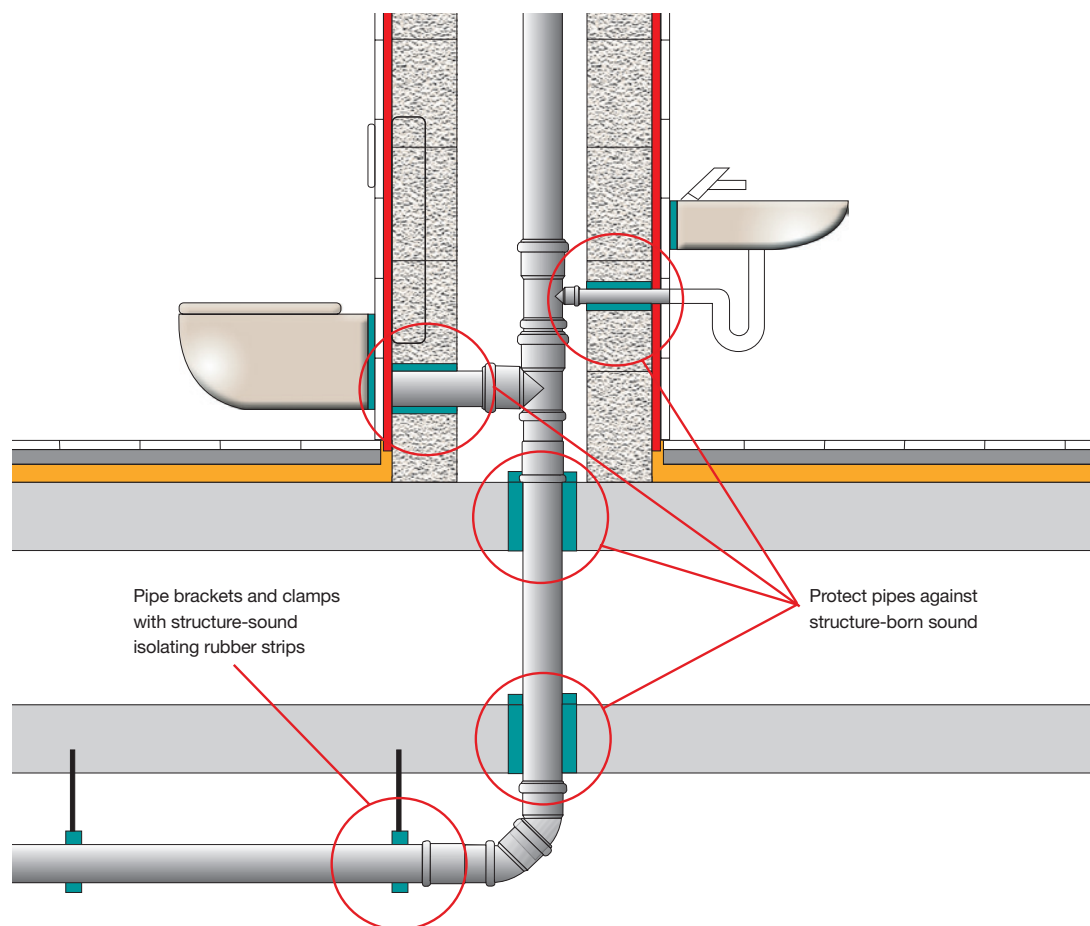

Figure 9: Sound insulation of waste water systems.

## 4. Design of the waste water system

### 4.1. Installation and layout principles for waste water drainage systems

The technical aspects of waste water drainage systems have been regulated in Europe for some time by an extensive set of standards established in the course of ongoing European harmonisation, started in 2000 with BS EN 12056 (“Gravity drainage systems inside buildings”).

This European drainage system standard consists of five parts

- Part 1:** General and performance requirements
- Part 2:** Sanitary pipework, layout and calculation
- Part 3:** Roof drainage, layout and calculation
- Part 4:** Waste water systems, layout and calculation
- Part 5:** Installation and testing, instructions for operation, maintenance and user

May 2008 saw the publication of the updated version of DIN 1986-100 “Drainage systems for buildings and provisions for private ground [...] in relation to DIN EN 752 and DIN EN 12056”.

This standard contains additional technical requirements for drainage systems, based on the earlier German standard DIN 1986, Parts 1+2, which were not incorporated into the DIN EN 12056 set of European standards.

The current version of the standard (from 2016) has been reorganised into key points for better readability, including, for example:

- ④ Basic requirements for the design and completion of waste water and rainfall drainage systems
- ④ The installation of pipes inside and outside buildings
- ④ Requirements concerning the quality and quantity of waste water
- ④ Backflow prevention
- ④ Sizing of waste water and rainfall drainage systems

DIN 1986-100 is therefore an extension of European waste water regulations for application in Germany, with uniform technical provisions for the design, construction, operation and maintenance of drainage systems used for the disposal of waste water in buildings and on private property.

For the sake of completeness, we also include other parts of the above-mentioned DIN 1986.

- Part 3:** Specifications for service and maintenance
- Part 4:** Fields of application of sewage pipes
- Part 30:** Maintenance of waste water drainage systems



## 4. Design of the waste water system

### 4.2. List of definitions according to BS EN 12056

#### Waste water drainage system

Structural system for the collection, drainage, disposal and treatment of waste water in buildings and on private property.

#### Collecting pipe

Horizontally installed pipe for the collection of waste water from downpipes and connected lines not buried below ground or installed in foundations.

#### Downpipe

Perpendicular pipe for the collection of waste water from individual and collective inlets. It directs the flow of waste water to a collecting pipe or underground and collector pipe.

#### Collecting connection pipe

Pipe designed to collect waste water from various single connection pipes and direct it to a downstream pipe.

#### Single connection pipe

Pipe from a sink drain or other drainage outlet, designed to direct waste water to a downstream pipe.

#### Bypass pipe

Pipeline for connection pipes in the retention area of a downpipe offset or in the transition between a downpipe and a collecting pipe or underground and collector pipe.

#### Discharge unit (DU)

The average discharge rate of a sanitary appliance expressed in litres per second (l/s).

#### Frequency factor

Variable to take into account the frequency of use of sanitary appliance (dimensionless).

#### Waste water flow rate ( $Q_{ww}$ )

Total design flow rate from sanitary appliances in a drainage system or in a part of a drainage system in litres per second (l/s).

#### Continuous flow rate ( $Q_c$ )

Flow rate of all continuous flows, e.g. cooling water, etc. in litres per second (l/s).

#### Pumped water flow rate ( $Q_p$ )

Discharge rate of waste water pumps in litres per second (l/s).

#### Total flow rate ( $Q_{tot}$ )

The total flow rate is the sum of the waste water flow rate ( $Q_{ww}$ ) and continuous flow rate ( $Q_c$ ) and pumped water flow rate ( $Q_p$ ) in litres per second (l/s).

#### Hydraulic capacity ( $Q_{max}$ )

Maximum flow rate of air through a ventilating pipe or air admittance valve, measured at 250 Pascal (Pa) pressure drop, in litres per second (l/s).

#### Types of system

The many types of drainage system that currently exist are a result of widely ranging areas of application for sanitary equipment in different countries and the variety of technical procedures and regulations that govern such systems.

BS EN 12056 classifies European waste water drainage systems into four types.

### System I

Single downpipes with partly-filled connection pipes.

Sanitary drainage sources are joined to partly-filled connection pipes. These partly-filled connection pipes are designed for a filling factor (h/d) of 0.5 (50%), and are in turn connected to an individual waste water downpipe.

### System II

Single downpipes with partly-filled connection pipes.

Sanitary drainage sources are joined to connection pipes of reduced size. These connection pipes are designed for a filling factor (h/d) of 0.7 (70%), and are in turn connected to an individual waste water downpipe. This configuration is used mainly in Scandinavian countries. It is not used in Germany.

### System III

Single downpipe system with fully-filled connection pipes.

Sanitary drainage sources, which are linked via connection pipes and operated in a fully-filled state. These filled connection pipes have a filling factor (h/d) of 1.0 (100%). Each individual connection pipe is separately connected to the downpipe.

System III is the preferred configuration in English-speaking countries. It is not used in Germany.

### System IV

System with separate waste water downpipes.

Configurations corresponding to systems I, II and III can also be divided into a waste water downpipe that collects waste from toilets and urinals and a waste water downpipe designed to collect waste water from all other drainage sources. This configuration is mainly used in France. Its use in Germany is only possible to a limited extent.

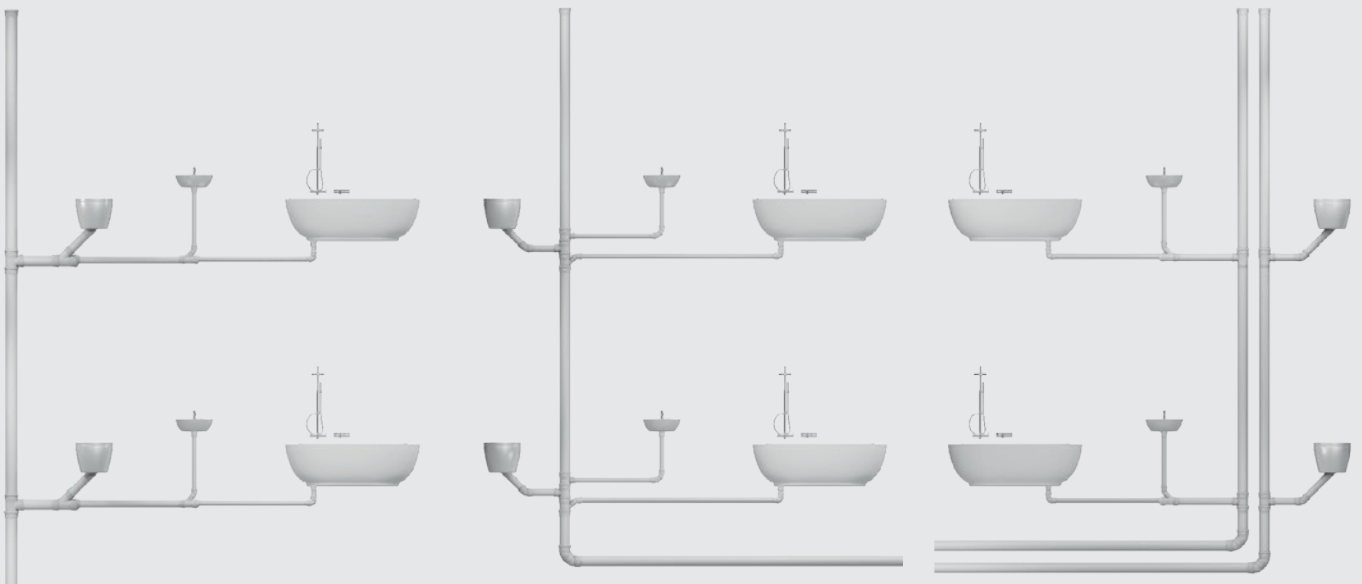

System I + II

System III

System IV

Figure 10: Waste water drainage systems in Europe.

# Wavin AS+

## 4. Design of the waste water system

### 4.3. Functional requirements

The dimensional specifications of waste water standards are based on various requirements:

- ⓘ The loss of trap water resulting from the flow of water must not reduce the total level of the water seal by more than 25mm in height
- ⓘ The trap water must not be sucked out by a vacuum or expelled by excess pressure
- ⓘ The waste water pipeline must be self-cleaning

The following sizing method applies to all gravity waste water drainage systems designed to dispose of domestic waste water. The layouts of industrial and commercial waste water drainage systems used in such places as swimming pools or factory buildings must be designed individually. Performance figures are based on the minimum internal diameters specified in the table in BS EN 12056-2.

Please note that the product standards applied to pipes and fittings used in Germany are based on outside diameters, which might lead to certain deviations with respect to the tables in BS EN 12056.

Nominal diameter DN	Minimum internal diameter Di (mm)
50	44
100	96
150	146
200	184

Nominal diameter (DN) with corresponding internal diameter  $D_{i_{min}}$  as per Table 1, BS EN 12056-2 (extract).

Nominal diameter DN	Minimum internal diameter Di (mm)
50	44
100	99.4
150	148.8
200	188

Nominal diameter and diameter used by Wavin AS+.

### Minimum fall

Compliance with the required minimum fall is vital for the proper drainage of waste water. Waste water standards specify different minimum falls, depending on the piping area concerned.

Table 2: Minimum fall for waste water pipes in different piping areas.

Area of piping	Minimum fall	Standard/section
Unventilated connection pipes	1%	BS EN 12056, Table 5 DIN 1986-100, Section 14.1.3.3
Ventilated connection pipes	0.5%	BS EN 12056, Table 8

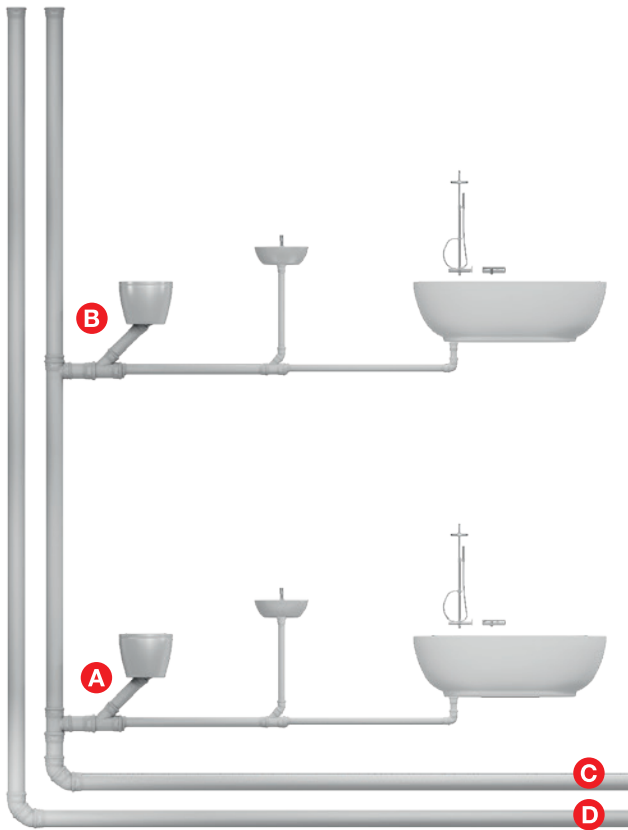

<b>A</b> Unventilated connection pipe	min. 1.0%
<b>B</b> Ventilated connection pipe	min. 0.5%
<b>C</b> Collecting pipe wastewater > DN100	min. 0.5%
Collecting pipe wastewater DN90	min. 1.5%
<b>D</b> Collecting pipe rainwater	1:DIN

Figure 11: Minimum fall for waste water pipes, example.

### Basis of calculations

The hydraulic calculations for a waste water system begin at the starting point (e.g. a sink, toilet or shower, etc.) and cover the rest of the piping, the layout of which depends on the items included.

- ④ Single connection pipe
- ④ Collecting connection pipe
- ④ Downpipe
- ④ Collecting pipe
- ④ Underground and collector pipe

Please refer to the following pages of the manual for further details of the areas covered by the waste water drainage pipes. The sum total quantities of waste water to be disposed of are normally based on various parameters.

The formula for calculating domestic waste water in accordance with BS EN 12056 is as follows:

### Basis of calculation BS EN 12056:

$$Q_{WW} = K \cdot \sqrt{\sum DU}$$

$$Q_{tot} = Q_{WW} + Q_C + Q_P$$

$Q_{WW}$  = Wastewater discharge  
[flow rate of waste water]

$Q_{tot}$  = Total wastewater discharge [l/s]  
[flow rate, total]

$Q_C$  = Continuous discharge [l/s]  
[flow rate, constant]

$Q_P$  = Pump flow rate  
[flow of discharge from pumps]

$DU$  = Design unit  
[design unit]

# Wavin AS+

## 4. Design of the waste water system

As in the equation  $Q_{ww}$ , this takes into account the discharge coefficient K and the discharge unit DU.

Frequency factor K describes the frequency of use of the sanitary drainage sources concerned, along with its simultaneity. Frequency factor K is not expressed in dimensional terms.

Table 3: Typical frequency factor K as per BS EN 12056 - 2.

Type of building	K
Non-regular usage (e.g. in residential properties, boarding houses and offices)	0.5
Regular usage (e.g. in hospitals, schools, restaurants and hotels) and/or showers)	0.7
Frequent usage (e.g. in public toilets)	1.0
Special usage (e.g. laboratories)	1.2

The discharge unit DU is described in terms of the expected amount of waste water for a given drainage source. 1 DU = 1 l/s.

**Backflow**

Connection pipes installed next to or opposite each other must be protected to prevent backflow. DIN 1986-100 contains corresponding suggestions for a hydraulically correct connection to a downpipe, as shown in the following illustrations.

WC + other drainage object

Opposite WC

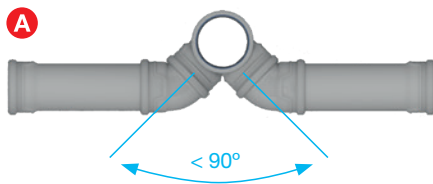

- Minimum dimensions**
- ⦿ Height offset not necessary
  - ⦿ Max. angle  $90^\circ$

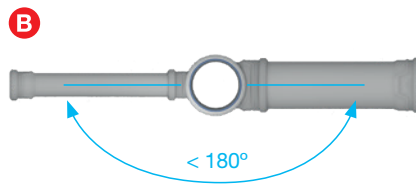

- Minimum dimensions**
- ⦿ Height offset min. 20cm
  - ⦿ Max. angle  $180^\circ$

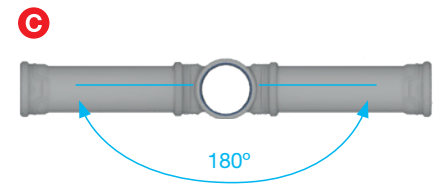

- Minimum dimensions**
- ⦿ Height offset not necessary
  - ⦿ Angle exactly  $180^\circ$

Example with Wavin AS+

Example with Wavin AS+

Example with Wavin AS+

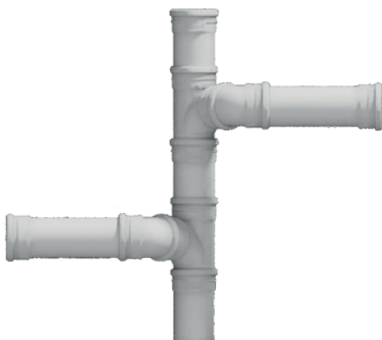

Branch DN 100

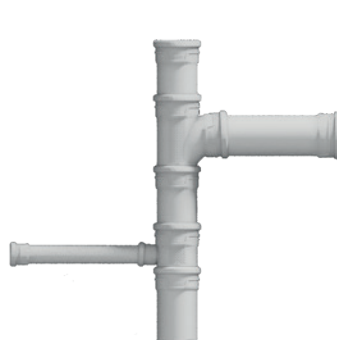

Different branches

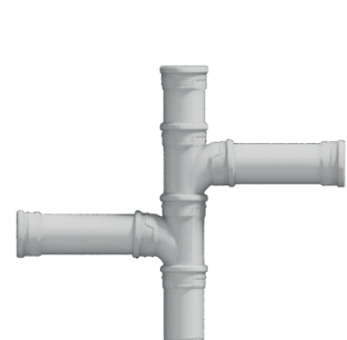

Branch DN 100

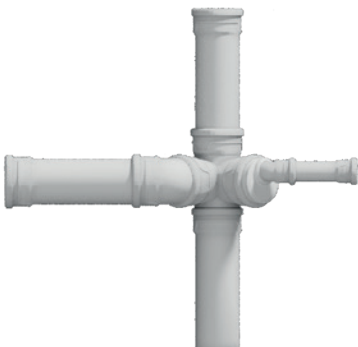

Corner branch with reducer

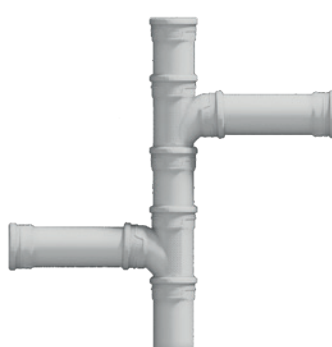

Branch DN 100



Double branch DN 100

Figure 12: Example of hydraulically correct connection to a downpipe

# Wavin AS+

## 4. Design of the waste water system

### Air-circulation pipes

Air-circulation pipes are used to ventilate collecting connection pipes which require such ventilation under certain circumstances, due to the length, height difference or the number of changes of direction; or for functional reasons.

Air-circulation pipes should have the same nominal diameter as the collecting connection pipes that they ventilate, as measured at the confluence with the downpipe. The cross-section of the pipe up to the start of the ventilation system should likewise be of this nominal diameter.



Figure 13: Air-circulation pipe.

### Bypass pipes

Bypass pipes are required under certain circumstances for downpipe offsets or points of confluence between downpipes and underground and collector pipes. Please also refer to the section of this manual that deals with downpipes.

Bypass pipes have the same nominal diameter as the downpipe, but have a maximum diameter of DN100. The size of the ventilation section (the upper part of the bypass pipe without waste water connection) can be calculated using the following table.

Please note that this table is only a partial extract from BS EN 12056, Part 2.

It shows only the System I values (i.e. the ones relevant to Germany)

Table 4: Extract from Table 7, BS EN 12056-2.

Hydraulic capacity ( $Q_{max}$ ) and nominal diameter (DN)

$Q_{max}$ (l/s)	Connection pipe / ventilation section (DN)
0.75	50/40
1.50	60/40
2.25	70/50
3.00	80/50**
3.40	90/60***
3.75	100/60

\*\* not applicable to toilets

\*\*\* not more than 1 toilet

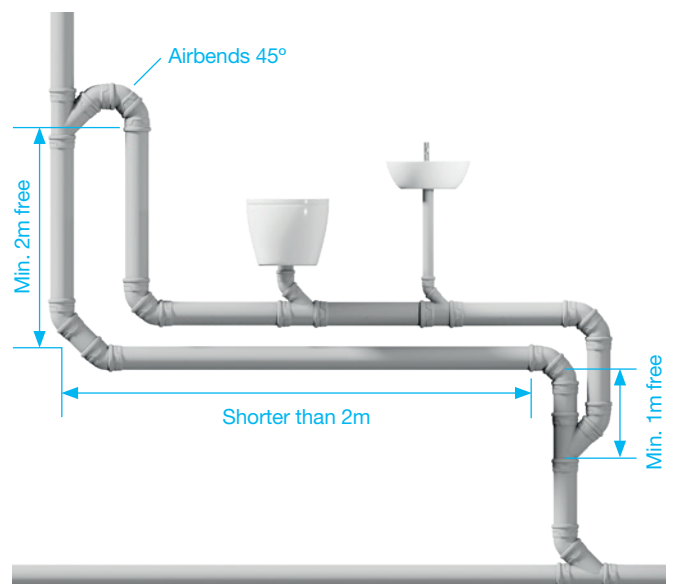

Figure 14: Bypass pipe conforming to DIN 1986-100.

### Ventilation valves

Ventilation valves may be installed in drainage systems equipped with primary ventilation systems, as an alternative to air circulation or indirect secondary ventilation systems designed to reduce vacuums in the piping system. Only ventilation valves conforming to BS EN 12380 may be used.

Ventilation valves may be used as a substitute for primary ventilated pipes in single/two-family residential properties or buildings with comparable residential units with a drainage system only for residential waste water, provided there is at least one downpipe running up to above roof height. In this case, the downpipe with the largest nominal diameter should be aerated/ventilated at above roof height.

Ventilation valves should be installed in such a way that allows them to be replaced without structural building work in the event of a defect. A sufficient supply of air must be guaranteed.

This area of application is subject to the operating temperature and installation position specified in Table 2, in accordance with BS EN 12380.

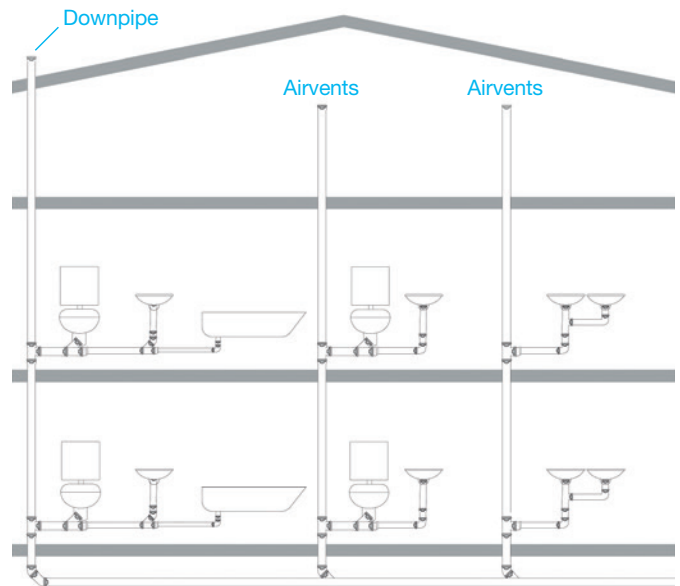

Figure 15: Use of ventilation valves in single/two-family residential properties

Ventilation valves must not be used in areas endangered by backflow or for the ventilation containers (e.g. pump stations).

Table 5: Operating conditions and designations of ventilation valves.

Determining factor	Area/position	Designation
Location: Usable beneath flow level <sup>a</sup> of the connection pipe of the connected drainage sources	Yes	A
	No	B
Temperatures	-20°C to +60°C	I
	0°C to +60°C	II
	0°C to +20°C	III

<sup>a</sup> Flow level within the meaning of the term “backflow level”, as defined in BS EN 12380

NOTE Valves corresponding to Designation I are designed for use in places where the ambient temperature at the point of installation (e.g. unheated attics) may drop to below freezing point over several days.



## 4. Design of the waste water system

### Rainwater pipes

Rainwater pipes must be capable of withstanding higher pressures under certain circumstances. Pressures above those foreseen may arise, for example, when overloaded sewers cause build-ups of rainwater. Thrust resistance must be sufficient to guarantee operating safety and reliability in such cases. To ensure this, the sleeves must be fastened using Wavin LKS clamps, for example.

The installation of rainwater pipes is also affected by the issue of condensation. Under certain operating conditions relating to room temperature, relative humidity in the room concerned and the temperature of the rainwater, the dew point of internal rainwater pipes may drop to below that specified.

Diffusion-resistant insulation should normally be fitted to internal rainwater pipes subject to any latent risk of condensation.

### Rainwater downpipes/calculation

The minimum dimensions must not be less than the connection diameter of the roof guttering.

The filling factor of r rainwater downpipes totals  $f \leq 0.33$

Downpipe deviations  $\leq 10^\circ$  are not taken into account when calculating the dimensions of the rainwater downpipe. If downpipe offsets are  $\geq 10^\circ$ , the sizing should be calculated subject to rules similar to those governing the layout of collecting pipes described in Chapter 4 of this waste water manual.

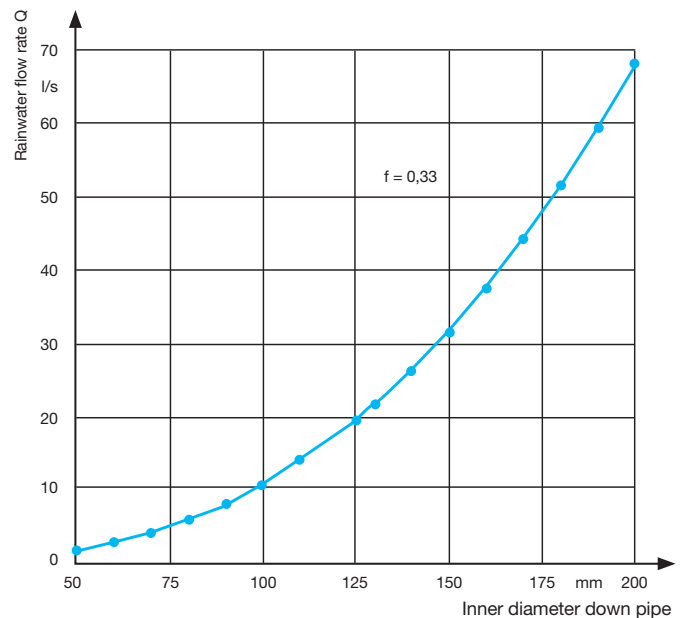

Figure 16: Drainage performance of rainwater downpipes.

Table 6: Nominal width and internal diameter, AS+.

Nominal diameter DN	Internal diameter Di (mm)
50	44
100	99.4
150	148.8
200	188

# Wavin AS+

## 5. Installation and jointing

Wavin has designed its low-noise systems to reduce noise emissions in concealed and visible installations. However, to ensure the system is leak-tight and to achieve a high level of soundproofing it is strongly recommended to follow the instructions given below.

### 5.1. Connecting Wavin AS+ to fittings and pipes

Wavin AS+ connections are fitted as follows:

- ⦿ Check position and condition of the seal in the socket. You may have to clean the socket and the seal
- ⦿ Clean the spigot-end of the pipe and/or fitting
- ⦿ In case of pipes: mark the insertion depth (socket length) on the spigot-end
- ⦿ Push the spigot-end into the socket according the insertion depth
- ⦿ The seal is pre-lubricated. For DN150 and DN200, additional lubrication might ease assembly

For pipes  $\geq 2$  meters:

- ⦿ Pipes & fittings connected to horizontal and vertical pipes  $\geq 2$  meters to be retracted 10mm to allow for thermal expansion
- ⦿ For vertical pipes, directly secure position with brackets to prevent slipping and eliminating the 10mm dilatation space

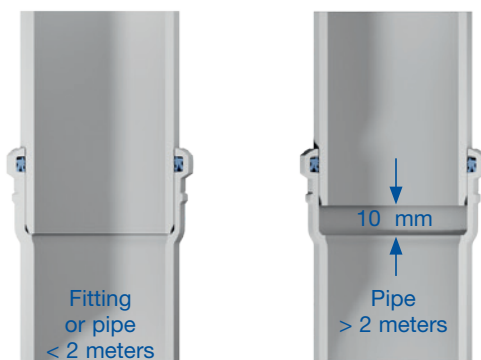
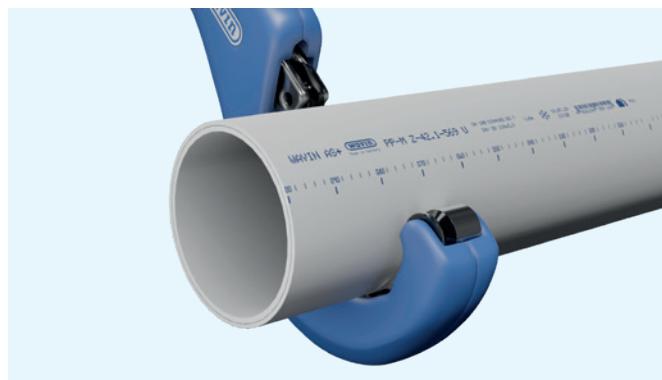

Figure 17: 10mm space for thermal expansion.

### Cutting pipes to size

Pipes can be cut to size using standard pipe cutters. When cutting pipes to length, do so at an angle of  $90^\circ$  to their axis. Remove any burrs or unevenness from the cut ends and rub down sharp edges.



For connections to Wavin AS+ fittings or sockets the pipe end needs to be chamfered. It is recommended to chamfer over a length of 5mm under a 15 degrees angle. This can be done by using standard chamfer tooling.

### Fixing

In principle, Wavin AS+ soil and waste water pipe systems should be installed tension-free and able to withstand changes in length. The pipes should be secured with sound-absorbing brackets that are compatible with the external diameter of the pipes and completely surround the circumference of the pipes. We recommend the use of Wavin low noise brackets, designed for securing to the brickwork with screws and plastic wall plugs. Metal anchors may also be used, although these do not favour sound insulation.



# Wavin AS+

## 5. Installation and jointing

### Installation in brickwork

DIN 1053, Sheet 1, Section 3.5 specifies that recesses and channels may be made in brickwork, provided they do not affect the stability or load-bearing capacity of the structure. In areas subject to high outside temperatures, thermal insulation measures must be applied (e.g. lagging of heating pipes). The key pipe dimensions to be taken into account when installing Wavin AS+ in brickwork recesses can be found in chapter 4 of this manual.

DN	Pipe $d_a$ mm	Coupling $d_M$ mm	Recess depth* $t_{\text{erf}}$ mm
50	50	67	125
100	110	129	179

\*These specified recess depths do not include pipe crossings.

### Installation in concrete

Like all hollow items, pipes are subject to buoyancy load forces when installed in concrete. All materials used in the pipe structure must be able to withstand these buoyancy loads. To this end, we recommend filling the pipe with water before fitting suitable fixing clamps to the existing steel reinforcement. Wavin Soil & Waste pipe systems (pipes and fittings) can be set in concrete immediately after installation. There is no need to account for any thermal length-expansion of the pipes once they have been installed in keeping with the installation instructions. The pipe sections should be secured properly so as to prevent any change in length, particularly during the pouring of concrete.

To prevent liquid concrete from seeping into the joints, seal the sleeves with adhesive tape (e.g. Tesa Krepp). Exposed pipe ends should also be sealed off. Pour the concrete into the area around the pipe and allow it to flow into the working space. When using a concrete vibrator to compact the concrete, be sure not to come into direct contact with the pipe. If noise-insulating measures are required, insulate the pipe with suitable lagging material before starting work.

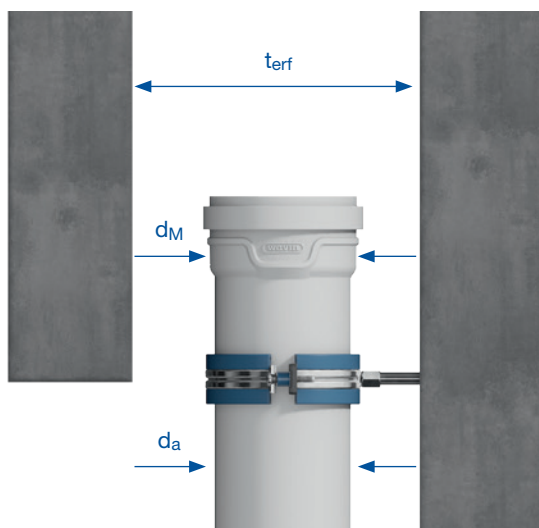

Figure 18: Example.

### Floor crossings

Floor crossings should be made leak-resistant and sound-absorbent. If mastic asphalt is used to cover the floor, the pipe sections located near the floor crossings must be protected using a protection sleeve or heat insulating wrapping material.

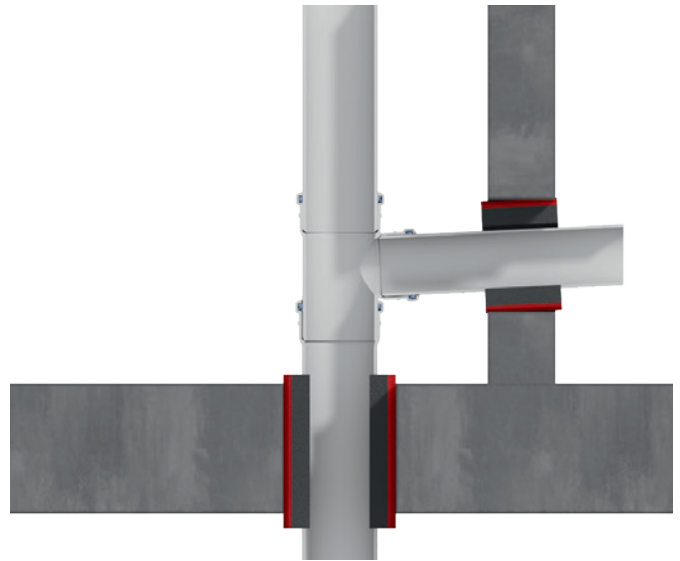

Figure 19: Floor and wall crossings.

### Roof drainage pipes in living areas

Roof drainage pipes projected through living areas can be installed as shown in the example opposite. The specific area weight of the casting should be at least equal to the wall.

The use of condensation insulation is also recommended for Wavin AS+. The installation of rainwater pipes is also affected by the issue of condensation. Under certain operating conditions relating to room temperature, relative humidity in the room concerned and the temperature of the rainwater, the dew point of internal rainwater pipes may drop to below that specified.

### Tensile resistant connection

Gravity drainage systems (for rain or waste water) can be subject to both planned and unplanned pressure surges. If Wavin AS+ or Wavin SiTech+ is used as a pressure line for a pump station, for example, the resulting pressure surges are planned. If an overloaded rainwater pipe is subject to hydrostatic pressure, however, this counts as an unplanned pressure surge.

For both types of pressure surge, the joints at changes of flow direction need to be secured to prevent them from detaching. The Wavin LKS clamp guarantees this for internal pressures of up to 2 bar.

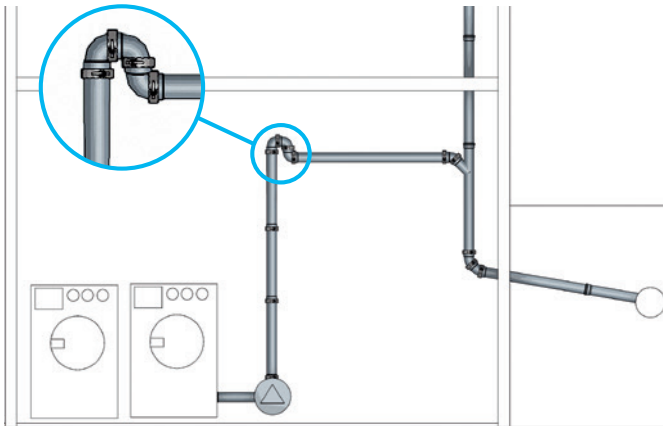

Figure 20: Tensile resistant connection.

Pressure surges may occur in any part of systems located downstream of pumps and pump stations. All fittings should therefore be secured using LKS clamps. Ensure that the fixings used are able to withstand such pressure surges. The system must be able to transfer dynamic loads to the supporting structure.

In the case of rainwater drainage systems, fittings located at changes of direction are critical. These fittings must therefore be equipped with LKS clamps. Vertical pipes (downpipes) do not require separate LKS clamps. Provided that the fixing specifications provided by us in this manual are observed, the joints on these sections will be suitably secured by the LKS clamp fitted where the change of direction occurs.

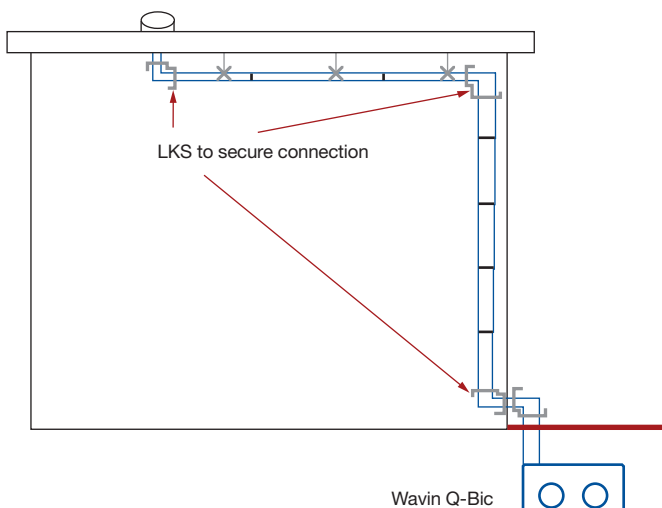

Figure 21

Wavin LKS clamps are available for use with Wavin AS+ sound-insulating pipe systems in sizes DN 50 to DN150.

For details of the required collar sizes and corresponding article numbers, please refer to page 56 of our AS+ range.



Figure 22: Wavin LKS Clamp.

### Soundproofing

If interior spaces are subject to the technical provisions of DIN 4109 (sound insulation in buildings), with pipe-borne noise not exceeding 30 dB(A), all work must conform to the technical building regulations applying to in-building systems with respect to the configuration of pipes in the context of the corresponding floor plan. Waste water pipes that run through living areas must not be exposed. If they are to run adjacent to such living areas, they may only be installed inside walls with a minimum specific area weight of 220 kg/m<sup>2</sup> (See DIN 4109-5).

The same conditions apply when installing in brickwork recesses conforming to DIN 1053, with pipes running along the other side of an adjacent wall subject to protection measures, where minimum wall dimensions of 220 kg/m<sup>2</sup> apply in the area of the recess. Shafts or recesses in brickwork must then be fitted with a supporting structure (matting or metallic mesh) that allows them to be plastered over to a minimum depth 1.5cm. There must be no sound bridges between the pipe and plaster covering. Preventive measures in this respect include pipe lagging of material classes A1, A2, B1, B2 (e.g. glass fibre, mineral wool or plastic).

As the routing of the pipe has a considerable influence on both the generation and reduction of noise, measures should be taken to minimise its impact. Falling waste water should therefore be directed downwards in stages where possible, i.e. not abruptly, as this would be technically unfavourable. In the case of buildings with more than three storeys (> 10 m), a noise-damping length of 250mm is fitted between the downpipe and the horizontal pipe. This can take the form of two 45° bends and a corresponding length of pipe (see Fig. 24).

# Wavin AS+

## 5. Installation and jointing

Alternatively, the use of one extended 45° bend and one normal 45° bend is recommended. The waste water pipes should likewise be dimensioned and installed in such a way that allows air to circulate freely around the water being drained.

Pipe clamps designed to comply with noise-prevention requirements must be fitted with a suitable rubber insert. In the case of bricked-up pipes, note that these must be secured to the underlying structure and not to the new brickwork. Wall and ceiling penetrations must be flexible.

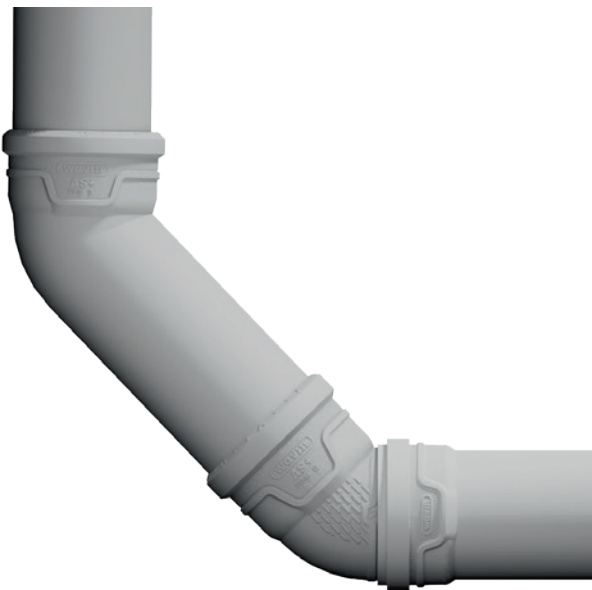

Figure 23: Extended 45° bend.

### Installation of pipes in existing structures

If a pipe is to be connected to an existing system, Wavin AS+ fitting should be used.

Repair coupler: Observe the following procedure when using Wavin AS+ repair coupler:

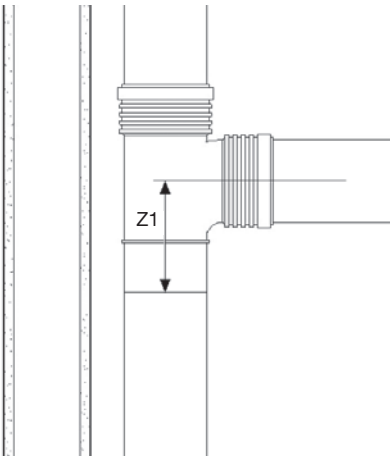

Figure 24: Example.

## Repairs using repair couplers

If a pipe section needs to be replaced or a branch needs to be added to the pipe system, please follow the following procedure.

1. Cut out the part which needs to be replaced. When inserting a branch at a later stage, please secure that the level of the branch is located at the right height. The Z1 value is mentioned for each branch in the product overview.



2. Install a short piece of temporary pipe halfway onto the repair coupler to secure a correct positioning of the rubber seal.

3. Install the free half of the coupler onto the existing pipe and slide the repair coupler completely over the existing pipe.

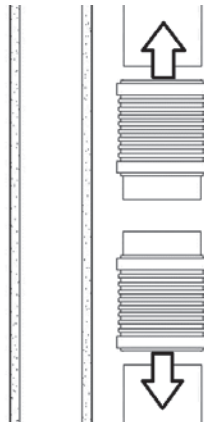

4. Secure that the pipe (or pipe and branch) has the same length as the part which has been cut out.
5. Measure half of the repair coupler length. Measure the same length from the new pipe ends and mark the pipe.

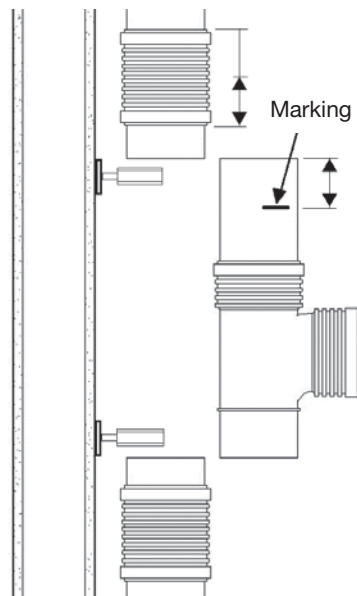

6. Install as close as possible to the two pipe ends wall plates for the fixed-point brackets and mount the threaded rod and back part of the brackets. When fixating the repair couplers with tensile resistant clamps this step can be skipped.
7. Install a tensile resistant clamp on each repair coupler to ensure no movement.

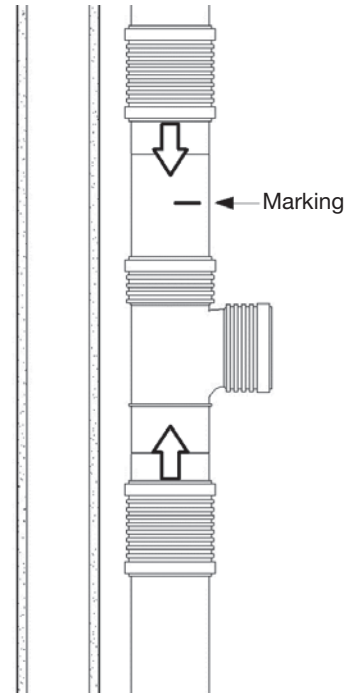

# Wavin AS+

## 5. Installation and jointing

### Repairs using a long socket and repair coupler

8. Finalise the installation of the fixed-point brackets or install a tensile resistant clamp on each repair coupler to ensure no movement.

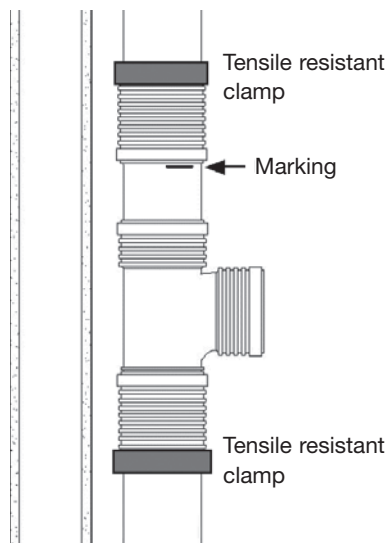
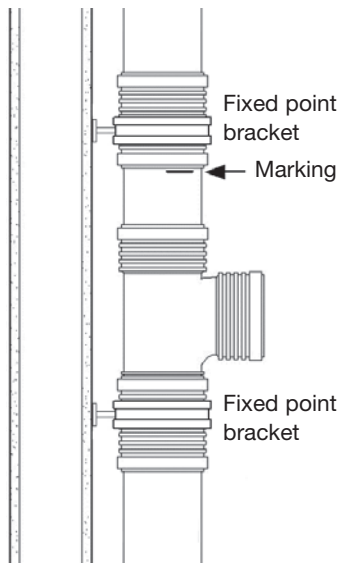

1. When inserting a branch at a later stage, please secure that the level of the branch is located at the right height. The Z1 value is mentioned for each branch in the product overview.

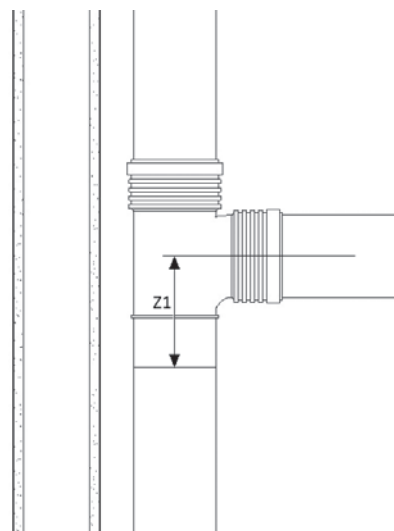

2. When inserting a branch, the length of the part to be cut out should have the length of the branch (L) + 20 mm + the length of the spigot of the long socket (Q).

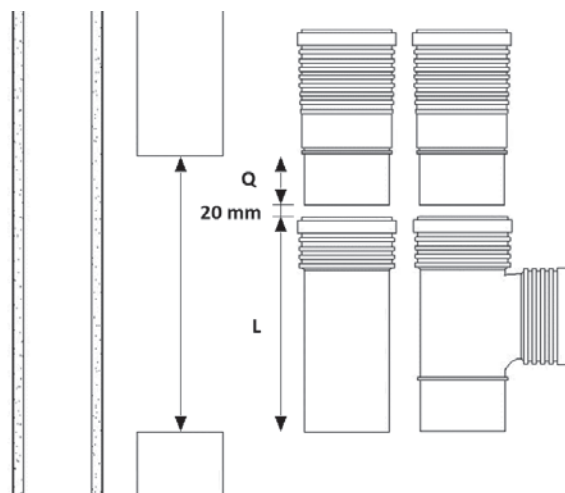

When replacing a piece of pipe, secure that the total length of the new socketed pipe (L) equals the length of the part cut out minus the length of the spigot of the branch (Q) minus 20 mm.

3. Install close to the two pipe ends wall plates for the fixed-point brackets and mount the threaded rod and back part of the brackets. When fixating the repair couplers with tensile resistant clamps this step can be skipped.

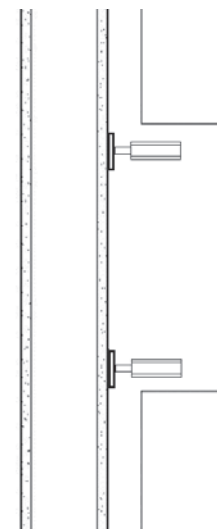

4. Install a short piece of temporary pipe halfway onto the repair coupler to secure a correct positioning of the rubber seal.
5. Install the free half of the coupler onto the existing pipe and slide the repair coupler completely over the existing pipe.

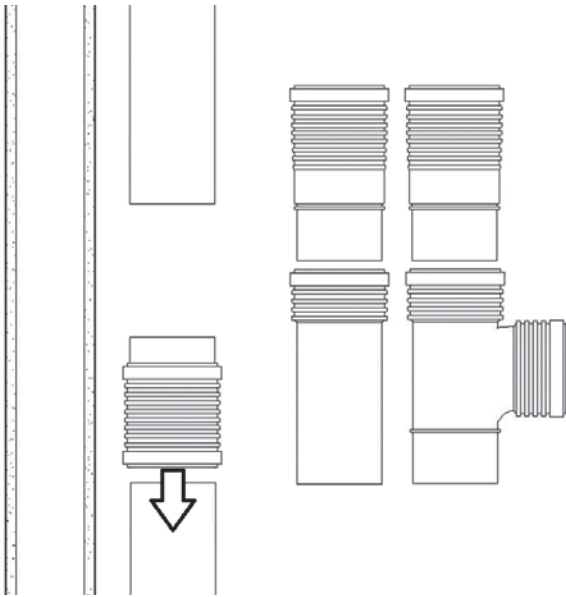

6. Slide the long socket over the other pipe end.

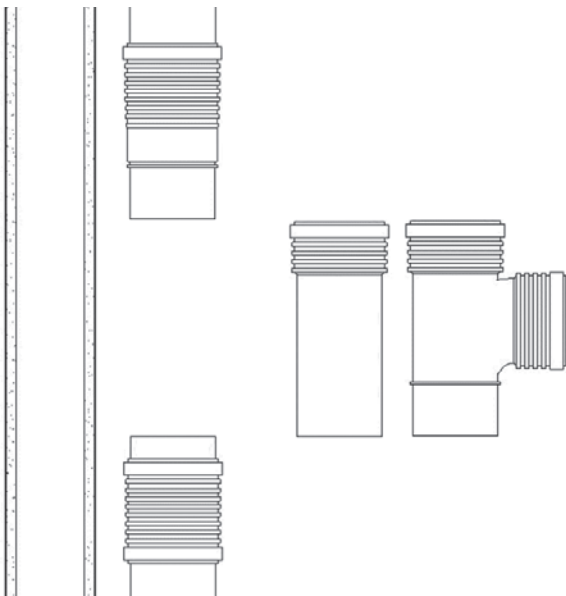

7. Push the socketed of the branch or pipe on to the long socket.

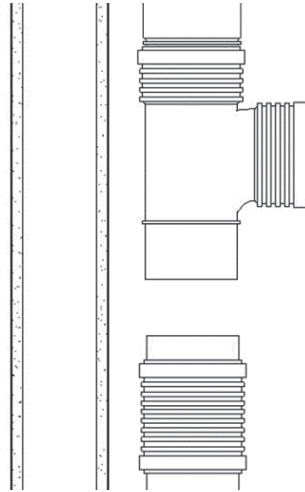

8. Push the long socket with the branch or pipe till the two pipe ends meet.
9. Finalise the installation of the fixed-point brackets or install a tensile resistant clamp on the long socket to ensure no movement.
10. If a pipe is inserted, measure half of the repair coupler length. Measure the same length from the new pipe end and mark the pipe.

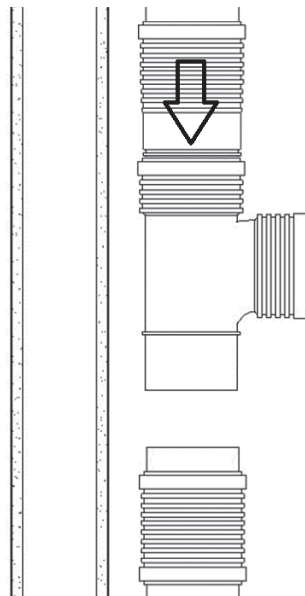



# Wavin AS+

## 5. Installation and jointing

11. Slide the repair coupler over the spigot end of the branch or to the marking on the pipe.

12. Finalise the installation of the fixed-point bracket or install a tensile resistant clamp on the repair socket to ensure no movement.

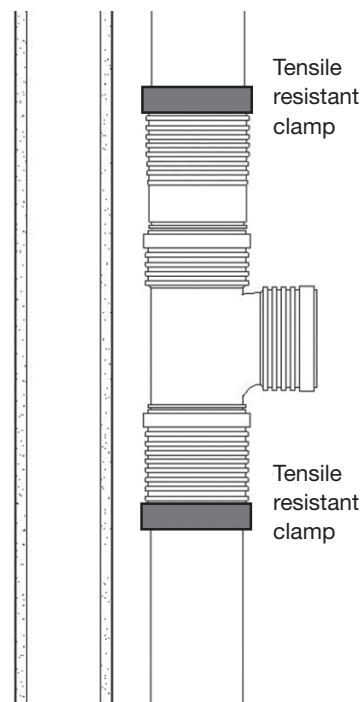
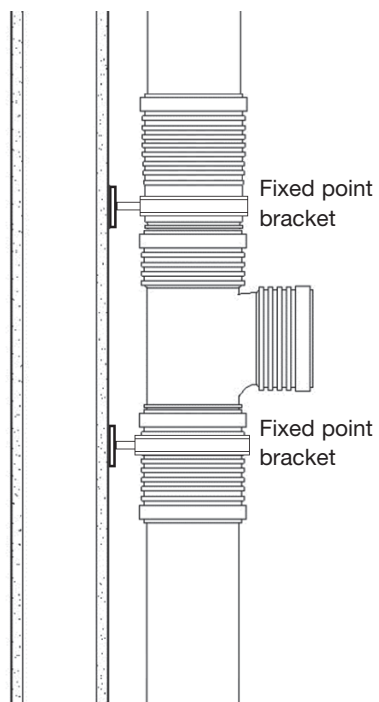
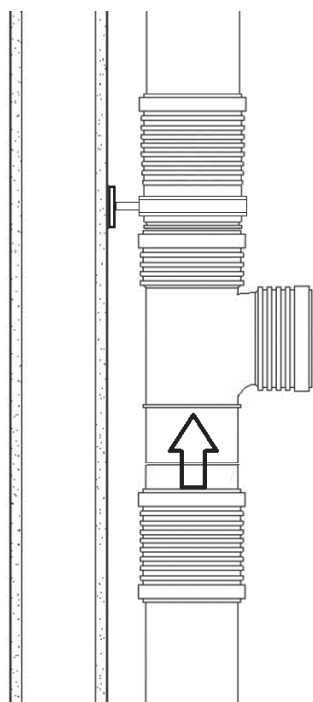

## Parallel branch

### Fixed to the finished floor, in wall-mounted configuration

When fitting to the finished floor in wall-mounted configuration, we recommend the use of a parallel branch matched to the connection dimensions of the wall-mounted item (WC element).

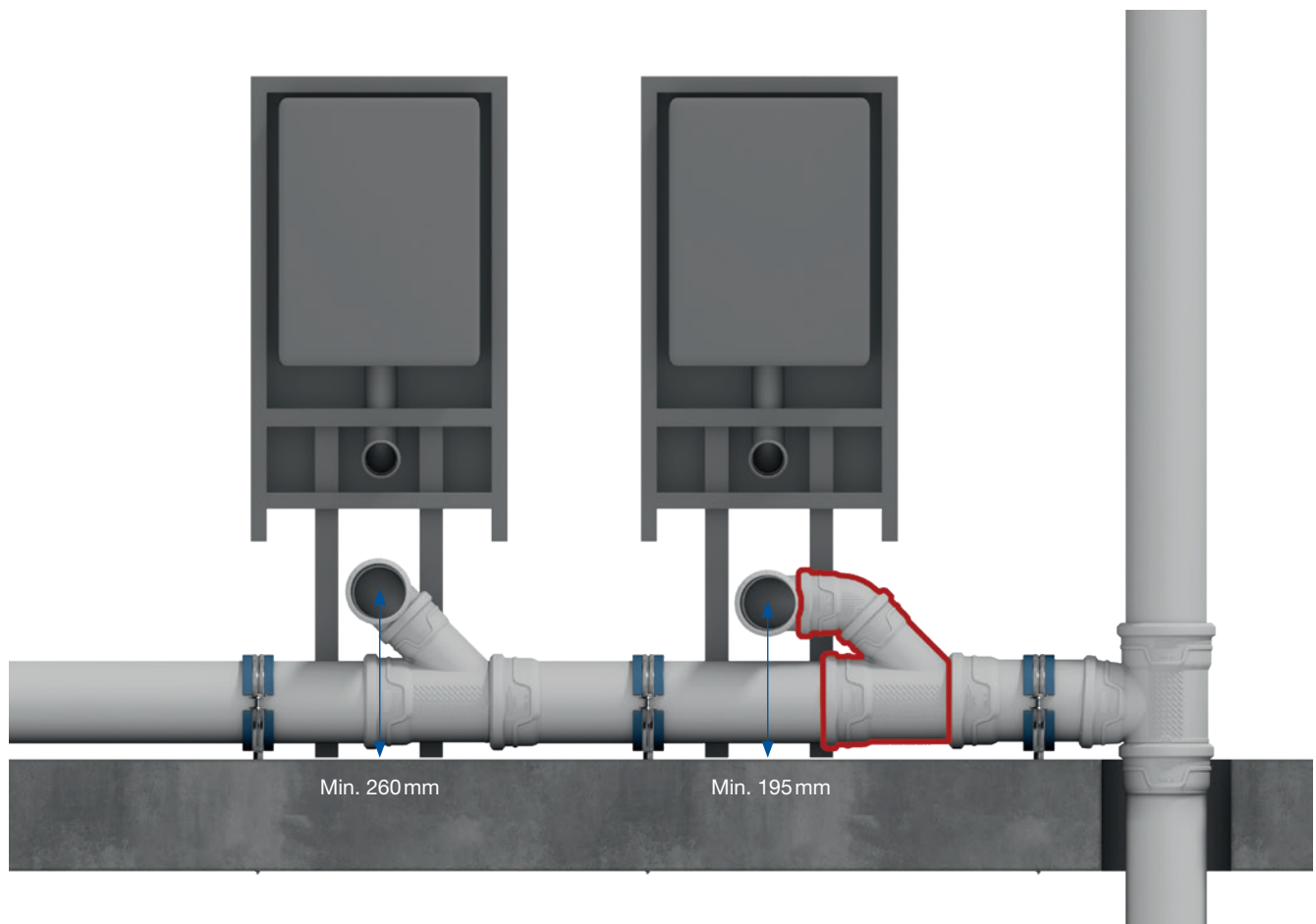

Figure. 25: Example of installation with or without parallel branch.

# Wavin AS+

## 5. Installation and jointing

### 5.2. General bracketing rules

#### 5.2.1. Bracket Fixing Instructions

##### Fixed Bracket

The fixed bracket creates a fixed point in the pipe system. The pipe or fitting cannot be moved through the bracket after the screws are tightened (no longitudinal movement is possible).

Use sound absorbing brackets, dimensionally compatible to the pipe diameter. Screw-pipe brackets with rubber inserts are recommended, which are fixed to the wall by screws and plastic plugs.

##### Sliding Bracket

By using sliding brackets, the pipe can still expand and contract due to temperature changes after the screws are tightened. This make sure longitudinal movement is still possible once installed.

##### Changing from sliding to fixed

Wavin low noise brackets are usable as sliding and as fixed bracket. All brackets provided by Wavin are sliding as standard.

To change the bracket from sliding to fixed, a distance washer is removed from the bracket before installation. The sliding and fixed brackets can both be completely tightened until the bracket ears touch the distance washers. The distance washers make sure that in any situation, the clamping force on the pipe is perfect. This results in minimal structure borne sound transmission.

The distance washers also prevent over-tightening of the brackets, which could otherwise result in a reduction of sound performance.

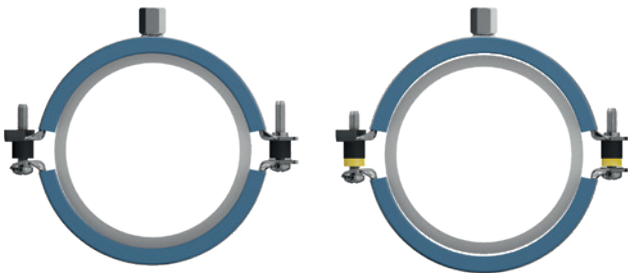

Fixed bracket \*removed distance washer

Sliding bracket \*distance washer in place



Changing from sliding to fixed: Remove the distance washer.



Removeable distance washer.

### 5.2.2. Bracket Arrangement

During installation of Wavin AS+ pipes, the following should be considered:

#### Vertical pipes:

- ⦿ To prevent the vertical stack sliding down, each pipe section between floors must be secured by one fixed bracket at the spigot-end
- ⦿ All remaining pipe brackets at subject pipe must be sliding brackets
- ⦿ Table 7 prescribing the maximum distance between brackets is to be respected

#### Horizontal pipes:

- ⦿ Every horizontally installed pipe length  $\geq 2$  meters should always be fixed with one fixed bracket at the spigot-end
- ⦿ All remaining pipe brackets at one pipe must be sliding brackets
- ⦿ Table 7 prescribing the maximum distance between brackets is to be respected

#### Notes:

- ⦿ For all changes of direction - e.g. a bend at the bottom of a down pipe - 1 bracket directly before and after the change of direction
- ⦿ In case multiple fittings are assembled, additional bracket(s) before/after this assembly might be required to ensure:
  - A downward slope in flow direction is in place (in case of horizontal pipes)
  - The centre of the assembly cannot be excessively displaced (in case of vertical pipes)
- ⦿ Ensure the materials are installed tension-free by properly aligning the brackets
- ⦿ To achieve a high level of sound proofing, generally pipe brackets should not be installed in impact areas (e.g. diameter reductions and changes of directions in the system)
- ⦿ Pipe brackets to be fixed to building materials with high specific area weight
- ⦿ In multiple storey buildings (from 3 storeys and more) the stack pipes of 110mm must be secured by additional fixing (stack pipe support) to prevent sliding. In this case we advise using the Wavin AS+ socketed short length with a fixed bracket (see figure 26)

Table 7: Pipe bracket spacing.

Nominal outer diameter DN/OD	Max distance between brackets	
	Horizontal (mm)	Vertical (mm)
50	750	1250
110	1500	2000
160	2000	2000
200	2000	2000

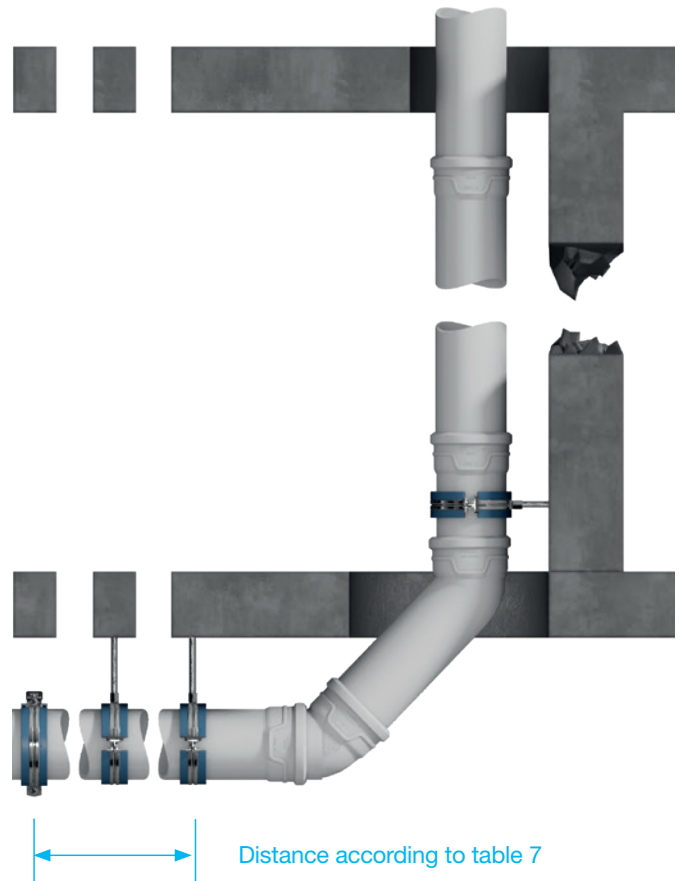
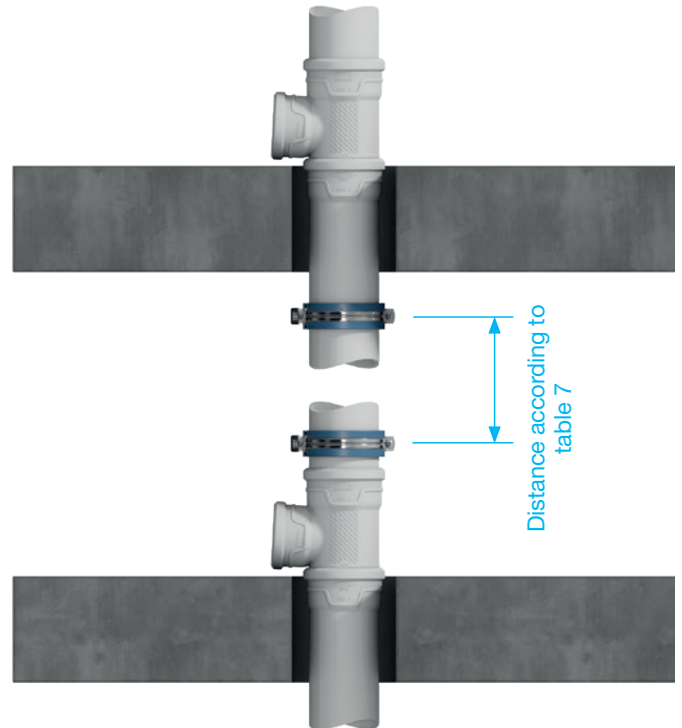

Figure. 26: Example horizontal and vertical installation.

# Wavin AS+

## 5. Installation and jointing

### 5.2.3. Max length of threaded rod

In the development of Wavin AS+ the product has fulfilled all testing procedures to ensure high quality. Wavin AS+ pipes and fittings comply to system tests as specified in EN1451-1. Wavin AS+ is approved via Type Testing (internal) as well as independently tested by accredited testing facilities.

Wavin AS+ pipes and fittings are continually subject to strict quality controls according to DiBt in Berlin. System requirements for leak tightness are prescribed in standards. Wavin AS+ is meeting leak-tightness requirements as set in the following standards:

- ④ EN ISO 1451-1 : leak-tight for 15 minutes with angular deflection of 2° at 0.5 bar
- ④ EN ISO 13257 : leak-tight for 15 minutes at 0.5 bar when filled after Temperature Cycle Test (1.500 cycles)

These requirements do not take into account fixation to a wall or ceiling. A proper installation is key to leak-tightness.

A poor installation cannot be compensated by a perfect system. Threaded rods are commonly used for suspension and fixing pipe brackets. It is important to keep in mind that threaded rods are designed to be used in tension and not to withstand bending moments.

For this reason, threaded rods to be used in AS+ installations have predefined maximum lengths. If the strength class is unknown, the maximum length can be retrieved from Table 8a and 8b. These tables were created, based on strength class 4.6.

Regarding internal pressure it is important to know what the impact can be in case maximum lengths are exceeded. In case the system gets clogged or otherwise is filled with water, an internal pressure builds up, the resulting forces cause the rods to bend and the joints might be pushed apart till leakage occurs.

The maximum pressure that can occur when the system gets clogged is determined by the vertical distance between the horizontal line and the lowest sanitary application to which this horizontal line is connected. In most cases, this distance is  $\leq 1$  metre.

Therefore, the maximum lengths of the threaded rods in Tables 8a and 8b are such that they can withstand bending moments due to 0.1 bar internal pressure.

In the following cases, a heavier fixation needs to be applied – especially at changes of direction where resulting forces cause threaded rods to bend – to ensure the system remains leak-tight.

- ④ The distance between bracket and wall / ceiling exceeds the maximum lengths as given in the table
- ④ The maximum pressure in the system can exceed 0.1 bar in case of clogging
- ④ There is a wish to hydrotest the installed system at a pressure  $> 0.1$  bar

In these cases it is advised to follow the method of statement for soil & waste pressure testing procedure or consult Wavin or bracket supplier.

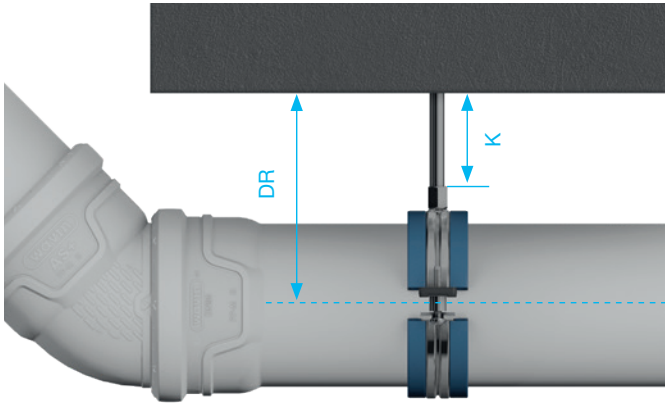

**Horizontal**

Maximum (DR) distance to the ceiling and maximum length (K) of threaded rod or threaded pipe

Table 8a: Fixing distance to the wall – Horizontal.

	M8		M10		M12		1/2"		1"	
	DR	K	DR	K	DR	K	DR	K	DR	K
DN/OD50	120	85	195	160	315	280	1535	1500	1535	1500
DN/OD110	105	40	145	80	205	140	915	850	1565	1500
DN/OD160			135	45	175	85	590	500	1590	1500
DN/OD200			150	40	175	70	510	400	1360	1250

*Note: for M12 threaded rods, 1/2" and 1" threaded pipes, adapter pieces are needed to connect to brackets.*

# Wavin AS+

## 5. Installation and jointing

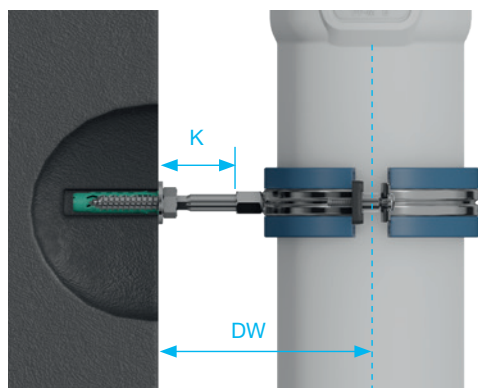

### Vertical

Maximum (DW) distance to the wall and maximum length (K) of threaded rod or threaded pipe

Table 8b: Fixing distance to the wall - Vertical.

	M8		M10		M12		1/2"		1"	
	DW	K	DW	K	DW	K	DW	K	DW	K
DN/OD50	95	60	155	120	245	210	1285	1250	1535	1500
DN/OD110			115	50	150	85	565	500	1565	1500
DN/OD160			120	30	140	50	390	300	1090	1000
DN/OD200					150	40	370	260	960	850

Note: for M12 threaded rods, 1/2" and 1" threaded pipes, adapter pieces are needed to connect to brackets.

### 5.2.4. Extended wall distance

If the distance from the wall to the pipe is bigger than you can solve with a single threaded rod according to the Table 8a and 8b with the general fixing distances, or in case the internal pressure might exceed 0,1 bar then there are multiple options to increase the distance.

It is important to know what the impact can be in case maximum lengths are exceeded. In case the system gets clogged, an internal pressure builds up, the resulting forces cause the rods to bend and the joints might be pushed apart till leakage occurs. In these cases the following options could be considered:

1. An option could be to consider suspended bracketing for socket support. Bracket assemblies are available for suspended sanitary and drainage installations in a building.
2. Another option is to use a 'wall bracket' to extend the distance between wall and pipe.
3. A third option could be to mount the pipe brackets to a mounting rail, that is installed parallel to the complete installation of the pipe.
4. A fourth option could be securing the connection via a LKS clamp. The joints at changes of flow direction need to be secured to prevent them from detaching. The Wavin LKS clamp guarantees this for internal pressures of up to 2 bar.

### 5.3. Low noise installation – bracketing types

Low noise installation is all about minimizing the transfer of sound (vibration) to connecting rooms. Two types of sound can be distinguished; airborne and structure borne sound. Airborne sound is reduced by the mass of the AS+ pipe, and structure borne sound is reduced by low noise bracketing. For more information about noise reduction, please refer to chapter acoustics.

Wavin offers two types of installation using the Wavin low noise bracket. The single bracket installation offering sound performance as low as 14dB(A), and the No-noise installation offering sound performance lower than 10dB(A).

#### 5.3.1. Low noise bracketing – single bracket – 14 dB(A)

The low noise installation makes use of a single “Wavin low noise bracket” that can be used as a sliding and a fixed bracket. The pipe bracket can be changed from sliding to fixed, by removing the distance washer. See 5.2.1. “Changing from sliding to fixed”.

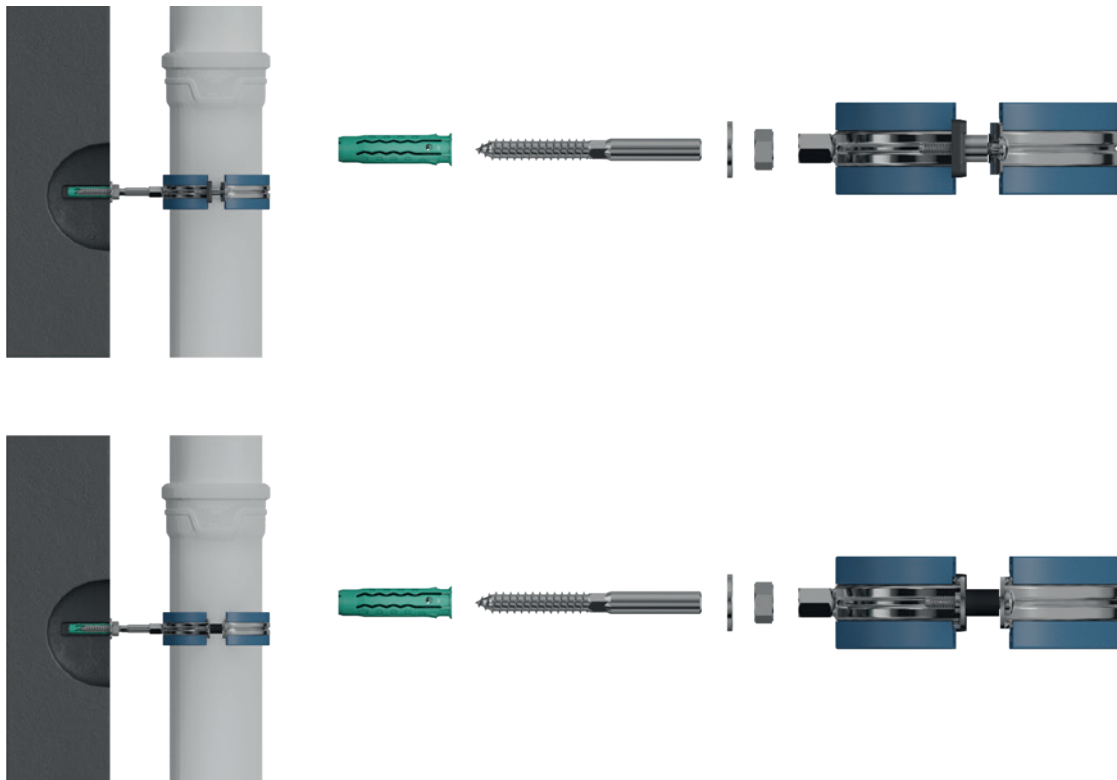
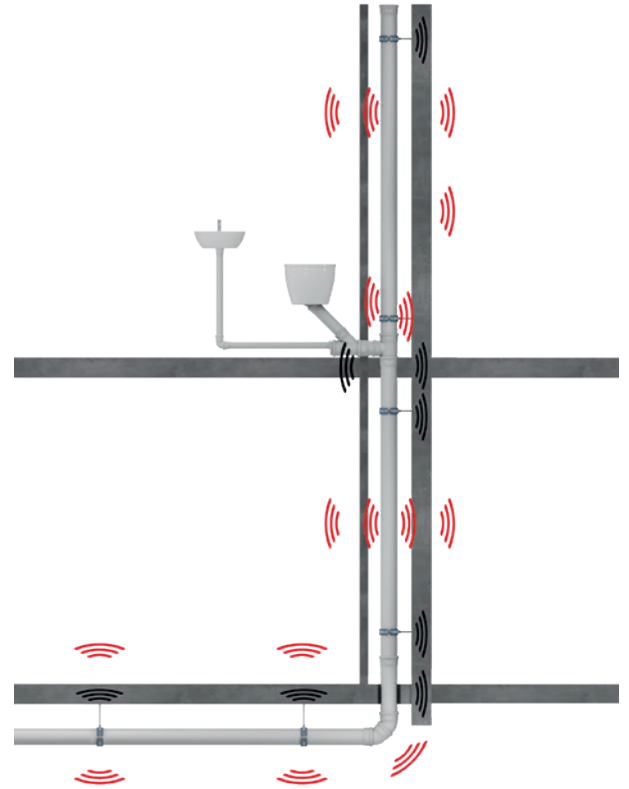

Figure 27: Low noise bracketing – 14dB(A).



# Wavin AS+

## 5. Installation and jointing

### 5.3.2 No-noise bracketing – Double bracket – lower than 10 dB(A)

The no-noise type installation makes use of the same “Wavin low noise bracket”, only difference in this installation is the stacked installation of the fixed bracket. The sliding bracket is the same as in the Low noise installation (see paragraph 5.3.1.). Each Wavin low noise bracket contains a rubber inlay that has foam sidewalls. The stacked installation offers further acoustic decoupling, for increased noise performance. The stacked installation consists of a sliding bracket that is mounted to the wall (not exceeding the threaded rod distances in table 8) and a fixed bracket that is mounted to the pipe. In final installed form, the fixed bracket is carried by the sliding bracket.

In the no-noise installation, the distance washers make sure that in any situation, the clamping force on the pipe is perfect. This results in minimal structure borne sound transmission. The distance washers also prevent over-tightening of the brackets, which could otherwise result in a reduction of sound performance.

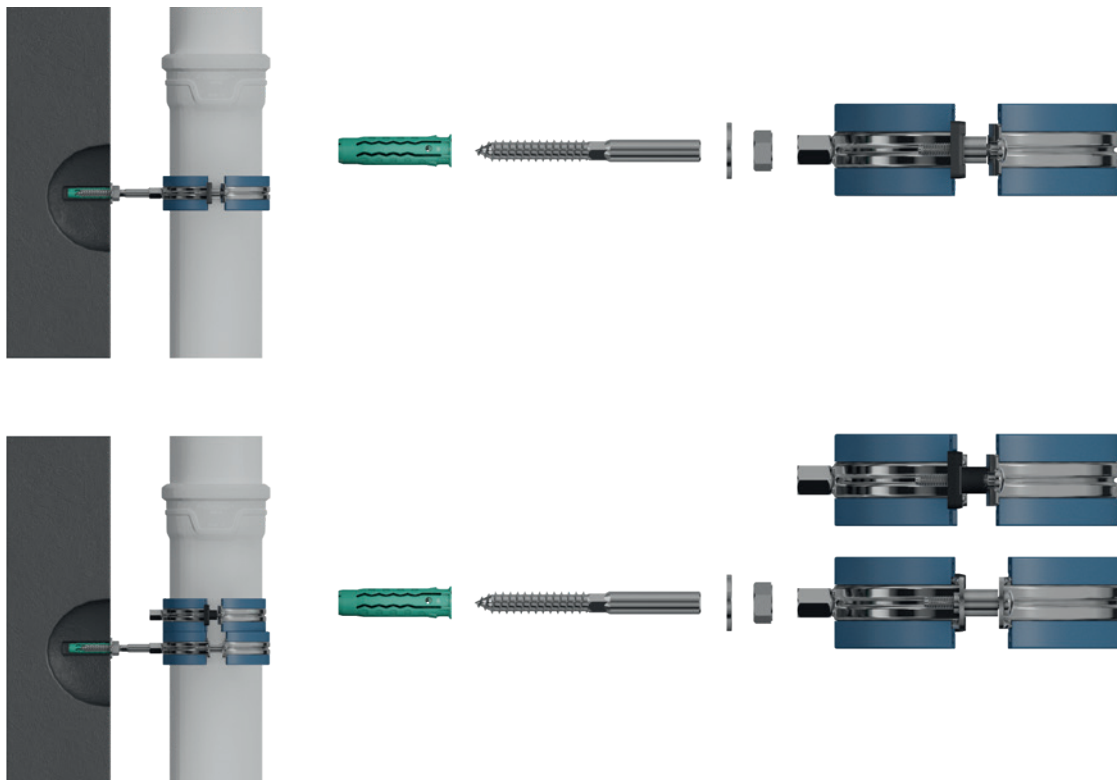

Figure 28: No-noise bracketing – lower than 10dB(A).

## 6. Fire protection

### 6.1 Fire behaviour classification

Fire behaviour of construction materials, e.g. piping systems and isolation materials, have been defined in fire classification classes as per DIN 4102-1. Construction materials are classified as combustible and non-combustible materials. According to DIN 4102-1 and EN 13501-1, PP, and thus Wavin AS+, is listed as B2 (normally flammable) or according European standard D S<sub>3</sub> do.

Table 9: Fire behaviour classification according to DIN 4102-1 and DIN EN 13501-1.

Criteria	Old Classification as per DIN 4102-1	New European classification according to DIN EN 13501-1		
		Additional criteria		
Non-combustible	A1	A1	–	–
	A2	A2	s1	d0
Non-readily ignitable (low flame spread)	B1	B	s1	d0
		C	s1	d0
		A2	s2/s3	d0
		B	s2/s3	d0
		C	s2/s3	d0
		A2	s1	d1/d2
		B	s1	d1/d1
		C	s1	d1/d2
		A2	s3	d2
		B	s3	d2
Normally ignitable (normal fire behaviour)	B2	D	s1/s2/s3	d0
		E	–	d0
		D	s1/s2/s3	d2
		E	–	d2
Readily ignitable	B3	F	–	–

In line with European standardization, the fire classification classes as per DIN 4102-1 are translated into the European DIN EN 13501. The accreditation is based on the standardised Single-burning-Item-Test (SBI) in conformity with BS EN 13823.

### 6.2 Fire resistance classification

The fire resistance classification provides the fire resistance duration of a specific construction material.

Table 10: Fire resistance classification.

Fire resistance classification	Fire resistance duration in minutes
F30	≥ 30 = fire retardant
F60	≥ 60 = high fire retardant
F90	≥ 90 = fire resistant
F120	≥ 120 = high fire resistant
F180	≥ 180 = extreme fire resistant

# Wavin AS+

## 6. Fire protection

Possible additions to these fire resistance classes, e.g. z.B. F90 A or F90 AB, can be explained as follows:

- A made of non-combustible materials
- B made of combustible materials
- AB in principle made of non-combustible materials

### 6.3 Wavin fire protection concept

Wavin Fire Protection Collar is in practice the best available solution. The Wavin Fire Protection Collar BM-R90 fully seal the wall or ceiling corridor in case of fire, due to special fire protection material which strongly expands by increased temperature.

The BM-R90 Fire Protection Collar (for Wavin AS+) is especially for sloped piping, suitable up to 45 degrees, and applicable for passages by sleeved pipes or fittings. In practice the collar is suitable to seal off almost any possible configuration.

### Fire Protection Collar BM-R90

- ⦿ For wall and ceiling crossings
- ⦿ Suitable for pipes with or without sockets and fittings
- ⦿ Also suitable for angled passages (up to 45 degrees)
- ⦿ Approved for ceiling installation
- ⦿ Applicable for Wavin AS+ from DN50 – 200
- ⦿ Fire classification F90

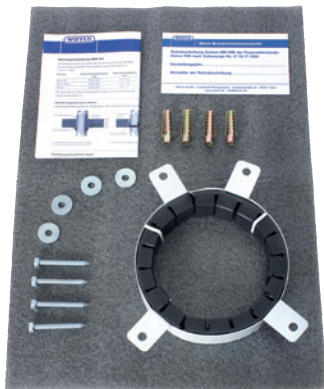

Figure 29: Fire Protection Collar BM-R90.

### 6.4 Assembly instructions

When the system is applied to a fire-resistant vertical (wall) or horizontal installation (floor) which separated a fire-risk area, only one Fire Protection collar is required. If the system is applied to a fire resistant vertical (wall) or horizontal (floor) installation which separated two fire-risk areas, use a Fire Protection collar on both sides.

#### Hole

Drill a circular hole into the wall or floor with a diameter of 2mm greater than the external diameter of the plastic pipe to be used.

#### Installing the pipe

Insert the PVC, PP, PE etc. pipe in the hole and clean the part the collar is to be applied to.

### Closing and sealing against fumes and gas

If there are any gaps between the pipe and the wall, seal these using putty or intumescent strips according to the thickness, to prevent the passage of fumes in the event of a fire.

### Cleaning the pipe

The expansion of the intumescent material in the collar completely closes the plastic pipes by a mechanical action. If the pipes are very dirty or have mortar residues, this may delay the action. Clean the surface of the plastic pipe in the point of installation of the fire protection collars.

NB: the fire protection collar can only prevent the passage of fire if it is properly installed

### Precautions

In the case of contact of the intumescent material with the eyes, wash delicately with soap and water. Keep out of the reach of children.

### Installation manual Wavin fire protection collar BM-R90

Wavin BM-R90 is a new fire protection sleeve designed for use with Wavin domestic waste water removal piping systems according to DIN 4102-11. It is suitable for use on piping with external diameters of up to 200mm and is able to provide a secure seal for use in all conceivable installation situations:

- ⦿ Right-angled wall and ceiling penetration
- ⦿ Lightly-constructed partition walls
- ⦿ Angled wall and ceiling penetration to 45°
- ⦿ For sealing over pipe collars (to 45°)
- ⦿ For installation under ceilings and in front of walls
- ⦿ Installation flush with ceiling surface

### BM-R90 installation instruction

The BM-R90 fire collar provides fire resistant sealing for wall and ceiling installation of the Wavin AS acoustic insulation systems and other selected Wavin soil and waste systems.

### General recommendations

#### 1. Positioning of the collars:

On both sides of a wall; on one side under/in a ceiling

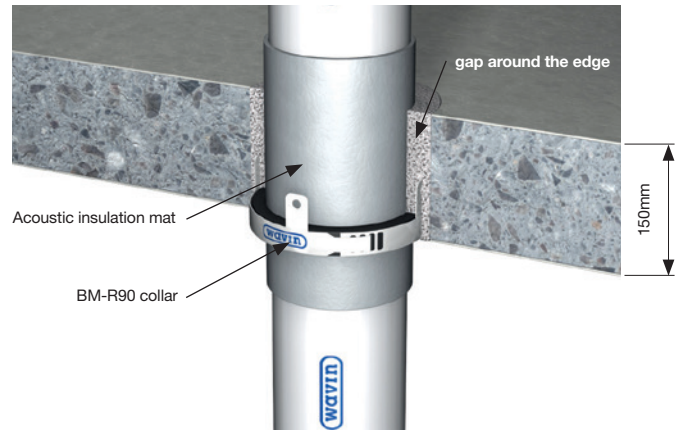

Figure 30: Straight installation with / without sleeve / socket.

#### 2. Wall & ceiling types:

At least 10cm thick solid concrete, aerated concrete and sand-lime brick walls as well as light dividing walls (stud walls: both sides clad with 12.5mm plasterboard) and solid concrete and aerated concrete ceilings at least 15cm thick.

#### 3. Structural acoustic insulation:

The acoustic insulation mat provided must be wrapped around the pipe where it passes through the wall or ceiling.

#### 4. Joint sealing between pipe and wall/ceiling:

To be packed to the full thickness of the wall or ceiling using mineral materials such as concrete, cement or plaster.



Figure 31: BM-R90 fire collar.

# Wavin AS+

## 6. Fire protection

### Components

The fire collars are made from powder coated sheet steel with a push-in fastening and tab fixings with an integrated intumescent material for reliable closure in the event of fire. Also included:

- ④ Insulation mat
- ④ Fixing kit
- ④ Identification label

Table 11: BM-R90 selection table for various types of Wavin AS+ pipe installation.

Wavin AS+ pipes DN	d (mm)	s (mm)	Straight installation	Straight installation with collar	Angled installation <sup>1)</sup> with sleeve or socket $\leq 45^\circ$ (mm)
56	50	3.0	63	75	90
100	110	5.3	110	125	140
150	160	5.6	160	180	200
200	200	6.0	200	-	-

<sup>1)</sup> The shape of the sleeve must be turned oval by pushing on both sides. In that way the shape of the collar can be adapted when leading-through the pipes (see also figure below)

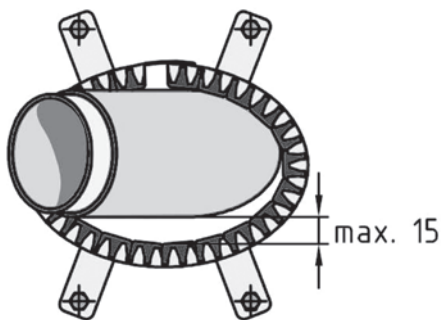

Figure 32: Maximum allowable gap between pipe and fire protection collar.

### Types of installation

#### I. Ceiling installation

Minimum requirements of the ceiling: min. 150mm thick concrete ceiling.

#### Flush ceiling installation

Wrap insulating mat around the pipe.

Open the collar and position it around the pipe, whilst hooking in the push-in fastening. Bend or angle the collar mounting tabs. Then install the collar flush with the ceiling. Fill the remaining ceiling gap with cement or concrete (see general recommendations (4)).

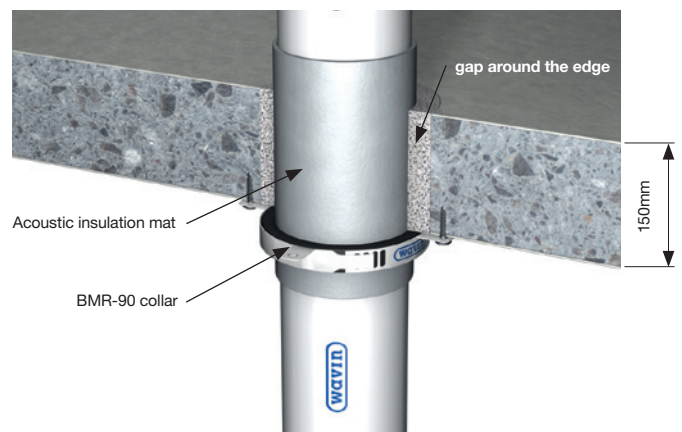

Figure 33: Straight installation without sleeve / socket up to 160mm.

#### II. Installation under the ceiling

#### Straight ceiling installation

Wrap insulating mat around the pipe. Open the collar and position it around the pipe, whilst hooking in the push-in fastening. Fill the remaining gap with cement or concrete (see general recommendations (4)). Hold the collar firmly against the ceiling and mark the positions of the mounting holes.

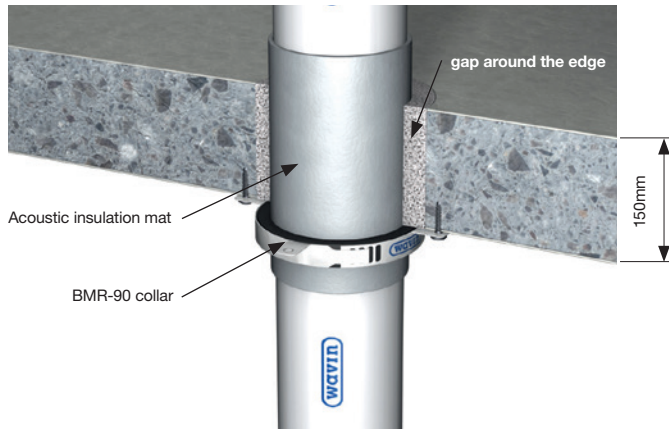

Figure 34: Straight installation with / without sleeve / socket.

Rotate the collar and drill the holes.

Insert plugs and fix the collar using screws and washers. (Mounting the collar using the washers, plugs and screws provided).

#### Angled ceiling installation

Wrap insulating mat around the pipe.

Open the collar and position it around the pipe, whilst hooking in the push-in fastening. Fill the remaining gap with cement or concrete (see general recommendations (4)).

Hold the collar firmly against the ceiling and mark the positions of the mounting holes.

Rotate the collar and drill the holes.

Insert plugs and fix the collar using screws and washers. (Mounting the collar using the washers, plugs and screws provided).

#### Installation distances between BM-R90 fire protection collars e.g. to external systems

The distance to external, tested systems (inspected and approved) must be at least 50mm between partitioned sections.

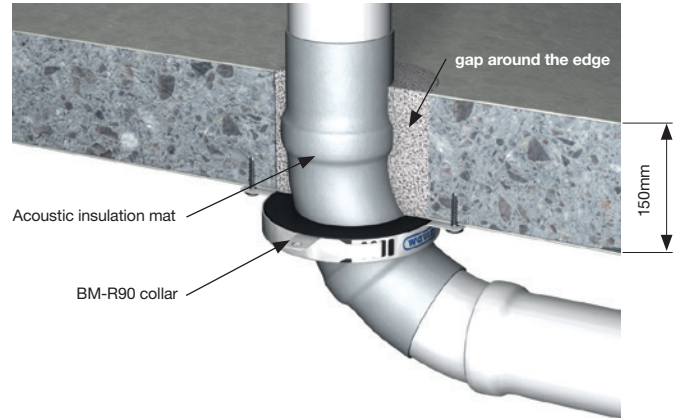

Figure 35: Angled ceiling installation  $\leq 45^\circ$  with / without sleeve socket.

If two Wavin BM-R90 feedthroughs are installed next to each other, the distance between the pipes must be at least 100mm in the case of special partitioned sections (sloping pipes, partition via sleeve/socket or for ceiling installations). In the case of straight pipes without sleeve/ socket in the partition area, the collar casings can adjoin each other (distance 0mm).

#### III. Wall installation

Minimum wall specifications: wall must be at least 100mm thick, made from concrete, aerated concrete, lime sandstone or lightweight partition walls (two-layer panelling on both sides with 12.5mm plasterboard panels and mineral wool infill). The pipe must be clamped on both sides at a distance of  $\leq 50\text{cm}$ . For wall feedthroughs, a collar should always be fitted on both sides of the wall.

Wrap insulating mat around the pipe. Open the collar and position it around the pipe, whilst hooking in the push-in fastening. Fill the remaining gap with cement or concrete (see general recommendations (4)). Hold the collar firmly against the ceiling and mark the positions of the mounting holes.

Rotate the collar and drill holes.

Insert plugs and fix the collar using screws and washers. (Mounting the collar using the washers, plugs and screws provided).

Repeat the steps described for the second collar required on the opposite side.

# Wavin AS+

## 6. Fire protection

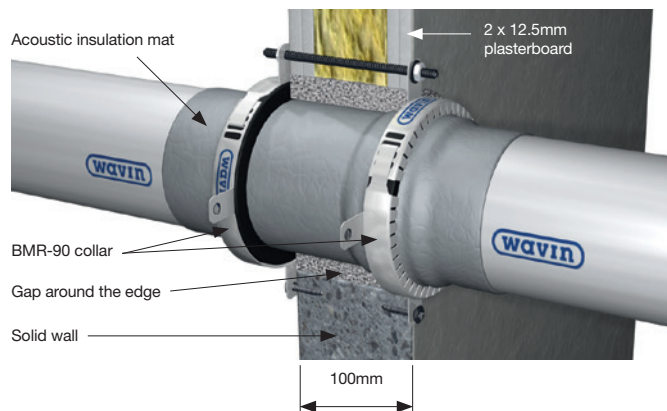

Figure 36: Straight installation with sleeve / socket.

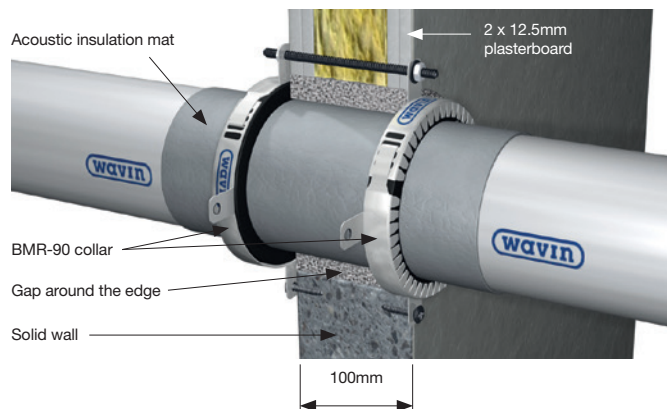

Figure 37: Straight installation without sleeve / socket.

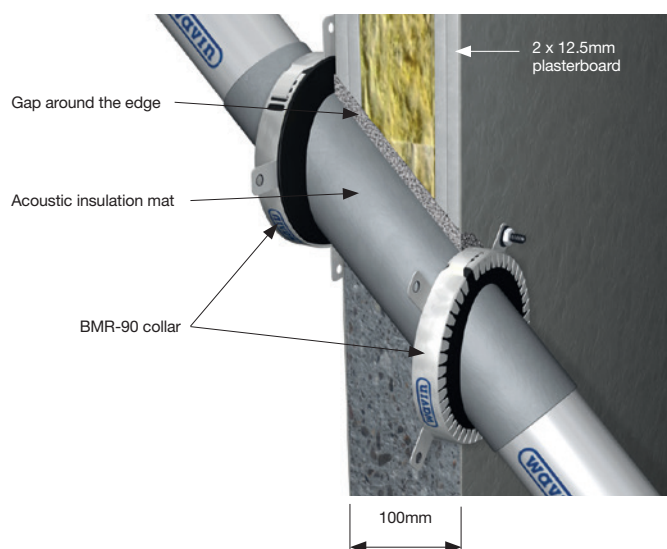

Figure 38: 45° angled installation with / without sleeve / socket.

The distance to external, tested systems (inspected and approved) must be at least 50mm between partitioned sections.

If two Wavin BM-R90 feedthroughs are installed next to each other, the distance between the pipes must be at least 100mm in the case of special partitioned sections (sloping pipes, partition via sleeve/socket or for ceiling installations). In the case of straight pipes without sleeve/ socket in the partition area, the collar casings can adjoin each other (distance 0mm).

### Note

The presented data, especially recommendations for the processing and use of our products are based on our knowledge and experience. Due to differences in material and working conditions that are outside the scope of our influence, we recommend that sufficient internal trials be conducted in each case to ensure the suitability of our product to the intended method and processing purposes. No liability will be accepted either on the basis of these instructions or from an oral advice, unless we are accused of gross negligence or deliberate malice.

# Wavin AS+

## 7. Packing, transport and storage

### Handling

Handle pipes and fittings with care. Excessive scratching or impact damage on pipes can affect the external structure or impair its sealing performance. Loose pipes must be unloaded by hand. If pipes have been inserted into other pipes, always remove the inner pipe first. We recommend the use of nyloncovered or plastic forks when unloading bundles of pipes with a forklift truck. Do not allow metal forks, hooks or chains to come into contact with the pipes. Do not use extended forks. If you intend to load or unload with a crane or excavator arm, attach a sling of sufficient width at the centre of the pipes.

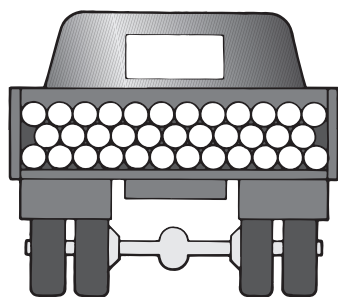

Transport of loose Wavin pipes.

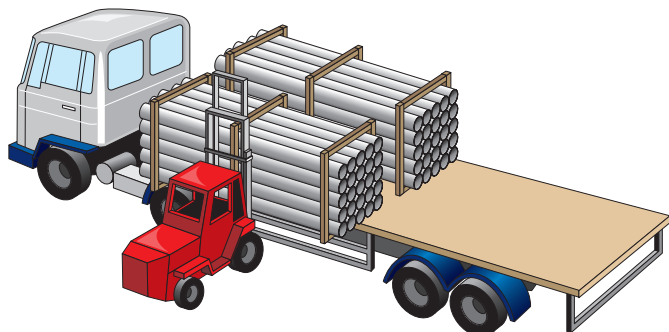

Unloading strapped pallets.

### Transport

If Wavin AS+ pipes are no longer in their original packing, they must be fully supported along their entire length and placed on a clean surface for transport. Avoid any bending of the pipes. Protect the pipe ends and fittings from impact damage.

### Storage

Always store pipes on a flat surface. Pallets may be stacked up to a maximum height of 1.5m without additional supports or side protection. Loose pipes must be held in place by at least 2 side supports spread evenly across their length. When storing, loose pipes may be stacked up to a maximum height of 1.5m, preferably supported along their entire length. If this is not possible, place wooden supports with a minimum width of 75mm under the pipes and spaced no more than 1m apart.

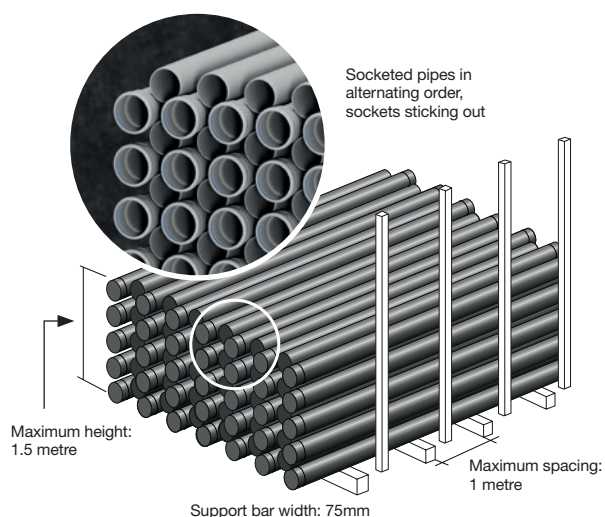

Stack pipes of different sizes separately or, if this is not possible, stack them in such a way that the largest diameter pipes are at the bottom. Pipes with sleeves should be stacked alternately so that they are supported along their entire length (see picture). Fittings are supplied in boxes and must be stored indoors. Do not subject fittings to heavy loads, as this can deform them.



# Wavin AS+

## 8. Product range overview

Product		DN 50	DN 100	DN 150	DN 200
Pipe		✓	✓	✓	✓
Double Socket Coupler		✓	✓	✓	✓
Bend		✓	✓	✓	✓
Long Bend			✓		
Branch		✓	✓	✓	✓
Double Branch			✓		
Corner Branch			✓		
Shower Branch			✓		
Manifold			✓		
Double Socket Sleeve		✓	✓	✓	✓

Product		DN 50	DN 100	DN 150	DN 200
Long Socket		✓	✓	✓	
Socket Plug		✓	✓	✓	
Reducer			✓	✓	✓
Access Pipe		✓	✓	✓	
Bracket		✓	✓	✓	✓
Covering Clamp type LKS		✓	✓	✓	
Gasket EPDM		✓	✓	✓	
Gasket NBR		✓	✓	✓	
BM-R90		✓	✓	✓	✓

# Wavin AS+

## Product details Acoustic soil system – Astolan® and PVC-U

### Pipe

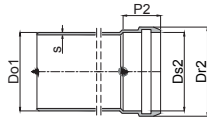

#### Pipe with socket

Material: Polypropylene with Astolan®

Nominal Size (mm)	Outer diameter Do1 = Ds2	Wall thickness s	Length of socket P2
50	50	3.0	46
100	110	5.3	59
150	160	5.6	71
200	200	6.0	86

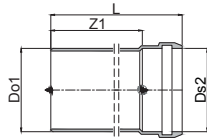

Nominal Size (mm)	Part Number	Dimensions (mm)			
		Do1	Ds2	L	Z1
50	3080063	50	51	3046	3000
100	3080030	110	111	209	150
100	3080034	110	111	2059	2000
100	3080036	110	111	3059	3000
150	3080044	160	160	221.4	150
150	3080050	160	161	3070	3000
200	3080056	200	200	3084	3000

### Fittings

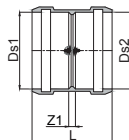

#### Double Socket Coupler

Material: Polypropylene with Astolan®

Nominal Size (mm)	Part Number	Dimensions (mm)			
		Ds1	Ds2	L	Z1
50	3080016	50	50	99	3
100	3080012	111	111	124	5
150	3080014	160	160	148	5
200	3080015	200	200	181	8

# Wavin AS+

## Product details Acoustic soil system – Astolan® and PVC-U

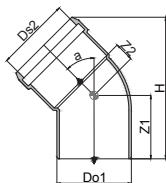

### Bends – 15°, 30°, 45°, 67°, 87°

Material: Polypropylene with Astolan®

Nominal Size (mm)	Part Number	Dimensions (mm)					
		a	Do1	Do2	H	Z1	Z2
50	3079965	15°	50	50	115	53	11
50	3079966	30°	50	51	122	57	13
50	3079967	45°	50	51	126	60	18
50	3079968	67°	50	51	124	68	23
50	3079969	87°	50	51	111	74	32
100	3079950	15°	110	110	157	70	17
100	3079951	30°	110	110	177	77	20
100	3079952	45°	110	110	192	85	32
100	3079953	67°	110	110	197	99	44
100	3079954	87°	110	110	186	114	61
150	3079959	15°	160	160	-	85	19
150	3079960	30°	160	160	-	96	28
150	3079961	45°	160	160	-	108	42
150	3079962	87°	160	160	-	151	84
200	3079963	45°	200	200	296	132	51
200	3079964	87°	200	200	303	185	42

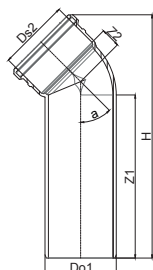

### Long Bend – 45°

Material: Polypropylene with Astolan®

Nominal Size (mm)	Part Number	Dimensions (mm)			
		Do1	Do2	H	Z1
100	3080026	110	110	25	250

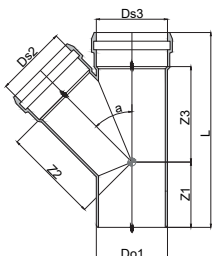

### Branch – 45° and 87°

Material: Polypropylene with Astolan®

Nominal Size (mm)	Part Number	a	Dimensions (mm)						
			Do1	Do2	Do3	L	Z1	Z2	Z3
50/50	3079996	45°	50	50	50	171	60	62	62
50/50	3079997	87°	50	50	50	150	75	29	29
100/50	3079982	45°	110	50	110	197	59	106	81
100/50	3079983	87°	110	50	110	178	85	59	36
100/100	3079981	45°	110	111	110	277	83	194	138
100/100	3079980	87°	110	110	110	253	136	77	56
150/100	3079991	45°	160	110	160	304	71	175	165
150/100	3079992	87°	160	110	160	256	124	87	6
150/150	3079994	45°	160	160	160	375	108	200	199
200/200	3079995	45°	200	200	200	460	128	250	250

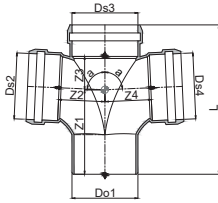

### Double Branch – 87°

Material: Polypropylene with Astolan®

Nominal	Part	Dimensions (mm)									
Size (mm)	Number	Do1	Ds2	Ds3	Ds4	L	Z1	Z2	Z3	Z4	
100/100/100	3080010	110	110	110	110	255	139	81	60	81	

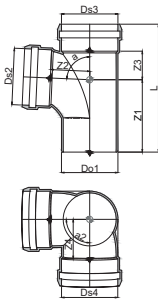

### Corner Branch – 87°

Material: Polypropylene with Astolan®

Nominal	Part	Dimensions (mm)									
Size (mm)	Number	Do1	Ds2	Ds3	Ds4	L	Z1	Z2	Z3	Z4	
100/100/100	3080008	110	110	110	110	251	122	139	128	139	

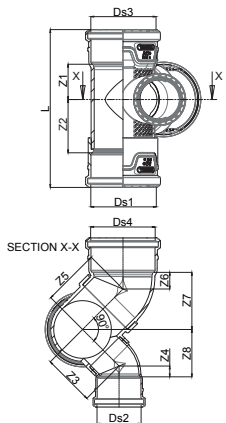

### Shower Double Branch – 87°

Material: Polypropylene with Astolan®

Nominal	Part	Dimensions (mm)									
Size (mm)	Number	Do1	Ds2	Ds3	Ds4	L	Z	Z1	Z2	Z3	
100/100/50	3080095	110	50	110	110	330	126	87	59	81	

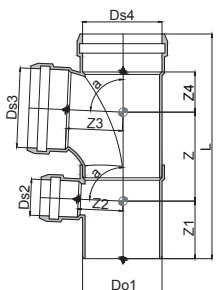

### Shower Double Branch – 87° left

Material: Polypropylene with Astolan®

Nominal	Part	Dimensions (mm)									
Size (mm)	Number	Do1	Ds2	Ds3	Ds4	L	Z	Z1	Z2	Z3	
100/100/50	3080096	110	50	110	110	330	126	87	59	81	

# Wavin AS+

## Product details Acoustic soil system – Astolan® and PVC-U

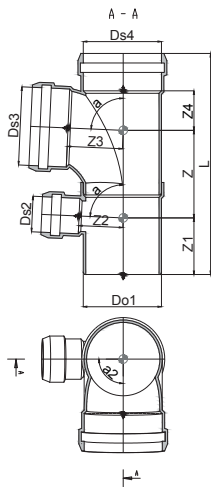

### Shower Double Branch – 87° right

Material: Polypropylene with Astolan®

Nominal Size (mm)	Part Number	Dimensions (mm)				
		Do1	Ds2	Ds3	Ds4	L
100/100/50	3080097	110	50	110	110	330

Dimensions (mm)						
Z	Z1	Z2	Z3	Z4	L	Part Number
126	87	59	81			3080097

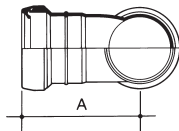

### S/SW Manifold Branch – Straight

- One solvent weld and one push-fit socket (right hand illustrated)

Material: PVC-U

Nominal Size (mm)	Part Number	Dimensions (mm)	
		A	Effective Length
110	3020490	180	132

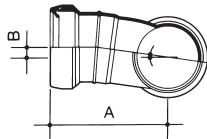

### S/SW Manifold Branch – 8°

- One solvent weld and one push-fit socket (right hand illustrated)

Material: PVC-U

Nominal Size (mm)	Part Number	Dimensions (mm)		
		A	B	Effective Length
110 LH	3020491	180	16	132
110 RH	3020496	180	16	132

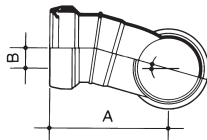

### S/SW Manifold Branch – 15.5°

- One solvent weld and one push-fit socket (right hand illustrated)

Material: PVC-U

Nominal Size (mm)	Part Number	Dimensions (mm)		
		A	B	Effective Length
110 LH	3020492	180	32	132
110 RH	3020497	180	32	132

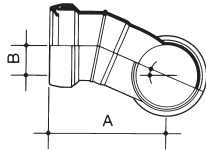

#### S/SW Manifold Branch – 23°

- One solvent weld and one push-fit socket (right hand illustrated)

Material: PVC-U

Nominal Size (mm)	Part Number	Dimensions (mm)		
		A	B	Effective Length
110 LH	3020493 ♡	180	48	132
110 RH	3020498 ♡	180	48	132

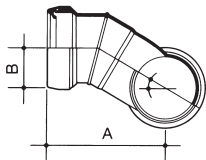

#### S/SW Manifold Branch – 30.5°

- One solvent weld and one push-fit socket (right hand illustrated)

Material: PVC-U

Nominal Size (mm)	Part Number	Dimensions (mm)		
		A	B	Effective Length
110 LH	3020494 ♡	180	64	132
110 RH	3020499 ♡	180	64	132

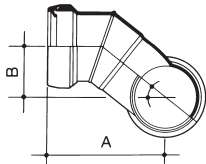

#### S/SW Manifold Branch – 38°

- One solvent weld and one push-fit socket (right hand illustrated)

Material: PVC-U

Nominal Size (mm)	Part Number	Dimensions (mm)		
		A	B	Effective Length
110 LH	3020495 ♡	180	80	132
110 RH	3020500 ♡	180	80	132

NOTE: All Manifold Branches are fitted with a gasket for direct connection to the outlets of WC's manufactured to BS 5503.

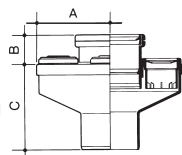

#### S/S Soil Manifold

- One plain end and one push-fit ring-seal socket
- Permits up to three 50mm connections to be made at floor level
- Complies with BS EN 12056-2:2000 clause ND. 3.3.2
- Make connections using 4Z124W, 2S355W or 2S356W (see below)
- Minimum installation aperture: 240mm square

Material: PVC-U, with Rubber seals

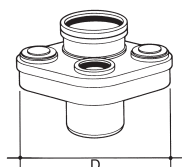

Nominal Size (mm)	Part Number	Dimensions (mm)			
		A	B	C	D
110	3065902 ♡	138	55	160	275

# Wavin AS+

## Product details **Acoustic soil system – Astolan® and PVC-U**



### All-Fit Reducer – 40:32mm

- Connects to 32mm plastic pipe to BS EN 1451-1/BS EN 1455-1/ BS EN 1566-1, or to copper pipe manufactured to BS 659 or BS 2871
- Use with 3020504 (below) when a bend is required

Material: Polypropylene

Nominal Size (mm)	Part Number	Dimensions (mm) A
40	3035106	54

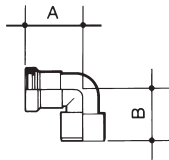

### All-Fit Reduction Bend – 50:40mm

- Connects to 40mm plastic pipe to BS EN 1451-1/BS EN 1455-1/ BS EN 1566-1, or to copper pipe manufactured to BS 659 or BS 2871

Material: Polypropylene

Nominal Size (mm)	Part Number	Dimensions (mm) A	Dimensions (mm) B
50	3020504	70	65

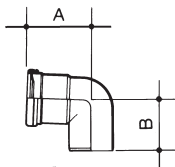

### All-Fit 90° Spigot Bend – 50mm

- Connects to 50mm plastic pipe to BS EN 1451-1/BS EN 1455-1/ BS EN 1566-1, or to copper pipe manufactured to BS 659 or BS 2871

Material: ABS

Nominal Size (mm)	Part Number	Dimensions (mm) A	Dimensions (mm) B
50	3020505	79	64

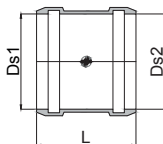

### Repair Coupler

Material: Polypropylene with Astolan®

Nominal Size (mm)	Part Number	Dimensions (mm) Ds1	Dimensions (mm) Ds2	Dimensions (mm) L
50	3080092	50	50	99
100	3080088	110	110	124
150	3080090	160	160	148
200	3080091	200	200	181

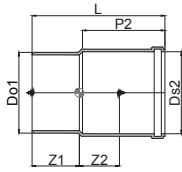

### Long Socket

Material: Polypropylene with Astolan®

Nominal Size (mm)	Part Number	Do1	Ds2	L	P2	Z1	Z2
50	3080023	50	50	184	105	57	60
100	3080019	110	110	219	137	69	88
150	3080021	160	160	264	164	85	123

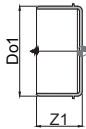

### End Cap

Material: Polypropylene with Astolan®

Nominal Size (mm)	Part Number	Dimensions (mm)	
Size (mm)	Number	Do1	Z1
50	3080106	50	51
100	3080103	110	65
150	3080105	160	76

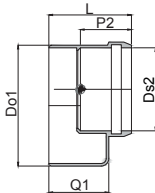

### Reducer

Material: Polypropylene with Astolan®

Nominal Size (mm)	Part Number	Dimensions (mm)				
Size (mm)	Number	Do1	Ds2	L	P2	Q1
100/50	3080078	110	51	90	53	79
150/100	3080082	160	111	114	59	98
200/150	3080084	200	160	130	24	114



### Reducer

- DN50mm spigot fits to Wavin AS+ DN50mm socket and reduces to 40mm plastic pipe to BS EN 1451, BS EN 1455 and BS EN 1566

Material: ABS

Nominal Size (mm)	Part Number	Dimensions (mm)
Size (mm)	Number	A
50/40	5Z124W	78



# Wavin AS+

## Product details **Acoustic soil system – Astolan® and PVC-U**

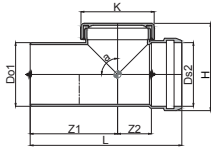

### Access Piece

Material: Polypropylene with Astolan®

Nominal Size (mm)	Part Number	Dimensions (mm)							
		a	Do1	Ds2	H	K	L	Z1	Z2
50	3079917	90°	50	50	84	65	164	82	37
100	3079913	90°	110	110	156	130	258	129	72
150	3079915	90°	160	160	213	130	271	135	68

## Accessories



### Wavin LKS-clamp

Material: Metal

Nominal Size (mm)	Part Number
50	4065138
100	4065141
150	4065143



### Gasket

Material: EPDM

Nominal Size (mm)	Part Number
50	4065145
100	4065188
150	4065190



### Gasket

Material: NBR

Nominal Size (mm)	Part Number
50	4065192
100	4025566
150	4025568



### Wavin System Bracket

Material: Rubber, Metal

Nominal Size (mm)	Part Number
50	4066449
100	4066452
150	4066454
200	4066455



### M10 Bolt

Material: Metal

Nominal Size (mm)	Part Number
80	3020511



### Firecollar BM-R90

Material: Metal

Nominal Size (mm)	Part Number
50	4026102
100	4026106
150	4026109
200	4026111

# Wavin AS+

## Annex I Chemical resistance list

### Legend

- + = Resistant
- o = Limited resistance
- = Not resistant
- SA = Saturated, aqueous solutions
- TP = Technically pure
- D = Diluted
- C = Commercial



Corrosive agent	Concentration	20°C PP	40°C PP	60°C PP
Acetaldehyde	TP	o	-	
Acetic acid	60%	+	+	
Acetic acid	10%			
Acetic acid	25%			
Acetic acid	60-95%	o		
Acetic anhydride	TP	+		
Acetone	TP	+	+	
Acetophenone	TP	+	o	
Acrylonitrile	TP	+	+	
Adipic acid	SA	+	+	
Air	-	+	+	+
Allyl alcohol	96%	+	+	+
Aluminium chloride	SA	+	+	
Aluminium fluoride	SA			
Aluminium sulphate	SA	+	+	
Alums	SA	+	+	
Ammonia, aqueous	SA	+	+	
Ammonia, gas	TP	+	+	
Ammonia, liquid	TP	+		
Ammonium acetate	SA	+	+	
Ammonium carbonate and bi	SA	+	+	
Ammonium chloride	SA			
Ammonium fluoride	20%			

Corrosive agent	Concentration	20°C PP	40°C PP	60°C PP
Ammonium fluoride	SA	+	+	
Ammonium fluoride	>10%			
Ammonium hydroxide	SA	+	+	
Ammonium nitrate	SA			
Ammonium phosphate, including meta	SA	+	+	+
Ammonium sulphide	SA	+	+	
Amyl acetate	TP	o		
Amyl alcohol	TP	+	+	+
Aniline	SA			
Aniline	TP	o	o	
Aniline hydrochloride	SA	+	+	
Anisole	TP	+	o	
Anthraquinone sulphonic acid, suspension	SA			
Antimony trichloride	90%	+		
Apple juice	C	+		
Aqua regia (HCl/HNO3)	03:01	-	-	-
Arsenic acid	SA			
Barium salts	SA	+	+	+
Beer	C	+	+	
Benzaldehyde	o.1%	+	+	
Benzaldehyde	TP			
Benzene — super (fuel for internal combustion engines)	C	o	-	-
Benzene (cleaning agent)	C	o		
Benzene-benzol mixture	80/20	o	-	-
Benzoic acid	SA	+	+	
Benzol	TP	o	-	-
Benzoyl chloride	TP	o		
Benzyl alcohol	TP	+	o	
Borax	D	+	+	
Borax	SA			
Boric acid	SA	+	+	
Brandy	C	+		
Bromic acid	10%			
Bromine gas	-	o	-	-
Bromine water	SA	o	-	-
Bromine, gas, dry	TP			
Bromine, liquid	TP	-	-	-
Butadiene	TP	o	-	-
Butane, gas	TP	+		
Butanol	TP	+	o	o
Butyl acetate	TP	o	-	-
Butyl glycol (butane diol)	TP	+		
Butyl phenol	SA	+		
Butyl phenol	TP			
Butyl phthalate	TP	+	o	o
Butyric acid	20%	+		
Butyric acid	TP			
Calcium carbonate	SA	+	+	+
Calcium chlorate	SA			
Calcium chloride	SA	+	+	+
Calcium hydroxide	SA			
Calcium hypochloride	SA	+		
Calcium nitrate	50%			
Calcium nitrate	SA	+	+	
Calcium sulphate	SA			
Calcium sulphide	SA			
Camphor oil	TP	-	-	-
Carbon dioxide	100%			
Carbon dioxide	SA	+	+	
Carbon dioxide, gas, wet/dry	TP	+	+	
Carbon disulphide	TP	+	-	-
Carbon monoxide	TP			
Carbon tetrachloride	TP	-	-	-
Castor oil	TP	+	+	
Caustic soda solution	Up to 60%	+	+	+
Caustic soda, see caustic soda solution		+	+	+
Chlorinated lime, slurry	-			
Chlorine ethanol	TP	+	+	
Chlorine water	SA	+	o	
Chlorine, gas, dry	TP	-	-	-
Chlorine, liquid	TP	-	-	-

Corrosive agent	Concentration	20°C PP	40°C PP	60°C PP	Corrosive agent	Concentration	20°C PP	40°C PP	60°C PP
Chloroacetic acid	85%	+	+		Hydrobromic acid	TP			
Chloroacetic acid	TP				Hydrochloric acid	20%	+	+	
Chloromethane	TP				Hydrochloric acid	Up to 35%	+	0	0
Chlorosulphonic acid	D	–	–	–	Hydrochloric acid, aqueous	Conc.			
Chlorosulphonic acid	TP				Hydrocyanic acid	10%	+	+	
Chrome alum	SA	+	+		Hydrofluoric acid	40%	+	+	
Chromic acid	1–50%	+	0	–	Hydrofluoric acid	70%	+	0	
Citric acid	D	+	+	+	Hydrogen	TP	+	+	
Citric acid	SA				Hydrogen chloride gas, dry	TP	+	+	
Coconut oil	TP	+			Hydrogen chloride gas, wet	TP	+	+	
Cooking salt, see sodium chloride					Hydrogen peroxide	30%	+	0	
Copper chloride	SA	+	+		Hydrogen peroxide	90%			
Copper cyanide	SA	+	+		Hydrogen sulphide	100%			
Copper fluoride	2%				Hydrogen sulphide	SA			
Copper nitrate	30%	+	+	+	Hydrogen sulphide	TP	+	+	
Copper nitrate	SA				Iodine tincture	C	+	0	
Copper sulphate	SA	+	+		I-propanol, see isopropanol		+	+	
Cotton-seed oil	TP	+	+		Iron II chloride	SA	+	+	
Cresol	Up to 90%	+	+		Iron II sulphate	SA			
Cresol	>90%	+			Iron III chloride	SA	+	+	
Cresylic acid	SA				Iron III nitrate	D			
Crotonic aldehyde	TP	+			Iron III sulphate	SA			
Cyclohexane	TP	+			Isopropanol	TP	+	+	+
Cyclohexanol	TP	+	0		Isopropyl ether	TP	0	–	
Cyclohexanone	TP	0	–	–	Lactic acid	10%			
Decahydronaphthalene (decalin)	TP	0	–	–	Lactic acid	TP			
Developers	C				Lanolin (wool fat)	C	+	0	
Dextrin	D	+	+		Lead acetate	SA	+	+	0
Dibutyl phthalate	TP	+	0	–	Linseed oil	TP	+	+	+
Dichloroacetic acid	TP	0			Magnesium carbonate	SA	+	+	+
Dichloroethylene	TP	0			Magnesium chloride	SA	+	+	+
Dichloromethane (methylene chloride)	TP	0	–	–	Magnesium hydroxide	SA	+	+	
Diethanolamine	TP	+			Magnesium nitrate	SA	+	+	
Diethyl ether	TP	+	0		Magnesium sulphate	SA	+	+	+
Diglycolic acid	30%				Maize germ oil	TP	+		
Diglycolic acid	SA	+	+		Maleic acid	SA	+	+	
Diisooctyl phthalate	TP				Malic acid	SA	+		
Dimethylamine	30%				Mercuric chloride	SA	+	+	
Dimethylamine	TP	+			Mercuric cyanide	SA	+	+	
Dimethylformamide	TP	+	+		Mercuric nitrate	D	+	+	
Diocetyl phthalate	TP	+	0		Mercury	TP	+	+	
Dioxane	TP	0	0		Methanol (methyl alcohol)	TP	+	+	–
Disodium phosphate	SA	+	+		Methyl acetate	TP	+	+	
Drinking water, chlorinated	TP	+	+	+	Methyl bromide	TP	–	–	–
Ethanediol	TP	+	+	+	Methyl ethyl ketone	TP	+	+	
Ethanol	40%				Methyl methacrylate	TP			
Ethanol	TP	+	+	+	Methylamine	Up to 32%	+		
Ethanolamine	TP	+			Methylene chloride, see dichloromethane		0	–	–
Ether, see diethyl ether					Milk	C	+	+	+
Ethyl acetate	TP	0	–	–	Mineral oils	C			
Ethylene chloride, mono and di	TP	0	0		Mineral water	C	+	+	+
Ethylene glycol, see ethanediol					MolaSAes	C	+	+	+
Fluorine	TP	–			Naphtha	C	+	–	–
Fluorosilic acid	40%				Naphthalene	TP	+	–	–
Formaldehyde (formalin)	40%	+	+		Nickel salts	SA	+	+	
Formic acid	1–50%	+	+	0	Nicotinic acid	D			
Formic acid	TP	+	–		Nitric acid	10%	+	+	
Fructose	C	+	+	+	Nitric acid	25%			
Fruit juices	C	+	+		Nitric acid	Up to 40%			
Furfuryl alcohol	TP	+	0		Nitric acid	10–50%	0	–	–
Gelatine	D	+	+	+	Nitric acid	Over 50%	–	–	–
Glacial acetic acid	TP	+	0	–	Nitric acid	75%			
Glucose	20%	+	+	+	Nitric acid	98%			
Glucose	SA				Nitrobenzene	TP	+	0	
Glucose	D	+	+	+	N-propanol	TP	+	+	
Glycerin	TP	+	+	+	Oils and fats (vegetable/animal)	–	+	0	
Glycolic acid	30%	+			Oleic acid	TP	+	0	
Glycolic acid	SA	+	–		Olive oil	TP	+	+	0
Heptane	TP	+	0	–	Oxalic acid	SA	+	+	–
Hexadecanol	TP				Oxygen	TP			
Hexane	TP	+	0		Ozone	TP			
Hydrobromic acid	10%				Paraffin oil	TP	+	0	
Hydrobromic acid	50%	+	–	–	Peanut oil	TP	+	+	

# Wavin AS+

## Annex I Chemical resistance list

Corrosive agent	Concentration	20°C PP	40°C PP	60°C PP	Corrosive agent	Concentration	20°C PP	40°C PP	60°C PP
Peppermint oil	TP	+			Sodium cyanide	SA			
Perchloric acid	10%				Sodium dichromate	SA	+	+	+
Perchloric acid	20%	+	+		Sodium fluoride	SA			
Perchloric acid	70%				Sodium hexacyanoferrate (II+III)	SA			
Perchloric acid, see perchloric acid					Sodium hydrogen sulphite (sodium bisulphate)	SA	+	+	+
Perhydrol, see hydrogen peroxide	30%		+	0	Sodium hydroxide, see caustic soda solution		+	+	+
Petroleum ether	TP	+	0		Sodium hypochlorite	13% effec. Chlorine	+	0	-
Phenol	D				Sodium nitrate	SA	+	+	
Phenol, aqueous	90%	+			Sodium nitrite	SA	+	+	
Phenylhydrazine	TP	0	0		Sodium orthophosphate	SA			
Phenylhydrazine chlorhydrate	TP	+	0	-	Sodium perborate	SA	+		
Phosphine	TP				Sodium phosphate	SA	+	+	
Phosphoric acid	50%				Sodium silicate (water glaSA)	D	+	+	
Phosphoric acid	Up to 85%	+	+	+	Sodium sulphate and bi	SA	+	+	
Phosphorus oxychloride	TP	0			Sodium sulphide	SA	+	+	
Phosphorus trichloride	TP	0			Sodium sulphite	40%	+	+	+
Picric acid	SA	+			Sodium thiosulphate	SA	+	+	
PotaSAium bichromate	40%				Soybean oil	TP	+	0	
PotaSAium bichromate	SA	+	+		Strength	D	+	+	
PotaSAium borate	SA	+	+		Sugar	SA	+	+	
PotaSAium bromate	SA				Sulphur dioxide, dry, wet	TP	+	+	
PotaSAium bromate	10%	+	+		Sulphur dioxide, liquid	TP	+		
PotaSAium bromide	SA	+	+		Sulphur trioxide	TP			
PotaSAium carbonate and bi	SA	+	+		Sulphuric acid	Up to 10%	+	+	-
PotaSAium chlorate	SA	+	+		Sulphuric acid	10-80%	+	+	
PotaSAium chloride	SA	+	+		Sulphuric acid	96%	0	-	
PotaSAium chromate	40%	+			Sulphurous acid	SA	+	+	
PotaSAium cyanide	>10%				Sulphurous acid	30%			
PotaSAium cyanide	SA	+	+		Tannic acid (tannin)	D	+	-	
PotaSAium fluoride	SA	+	+		Tartaric acid	D			
PotaSAium hexacyanoferrate (II+III)	SA				Tartaric acid	SA	+	-	
PotaSAium hydroxide	Up to 50%	+	+	+	Tetraethyl lead	TP	+		
PotaSAium hydroxide	60%				Tetrahydrofuran	TP	0	-	-
PotaSAium hydroxide solution, see potaSAium hydroxide					Tetrahydronaphthalene (tetralin)	TP	-	-	-
PotaSAium hypochloride	D				Thionyl chloride	TP	0	-	-
PotaSAium iodide	SA	+	+		Thiophene	TP	+	0	
PotaSAium nitrate (potash)	SA	+	+		Tin chloride II+IV	SA	+	+	
PotaSAium orthophosphate	SA				Toluene	TP	0	-	-
PotaSAium perchlorate	1%				Trichloroacetic acid	50%	+	+	
PotaSAium perchlorate	10%	+	+		Trichloroethylene	TP	-	-	-
PotaSAium perchlorate	SA				Tricresyl phosphate	TP	+	0	
PotaSAium permanganate	SA	+	-		Triethanolamine	D	-		
PotaSAium permanganate	20%				Trimethyl propane	Up to 10%			
PotaSAium persulphate	SA	+	+		Turpentine	TP	+	-	-
PotaSAium sulphate	SA	+	+		Urea	33%			
PotaSAium sulphide	D				Urea	>10%			
Potash, see potaSAium nitrate		+	+		Urea	SA	+	+	
Propane, gas	TP	+			Urine	C			
Propionic acid	50%	+			Vinegar (wine vinegar)	C	+	+	
Propionic acid	TP				Vinyl acetate	TP	+	0	
Pyridine	TP	0	0		Whisky	C	+		
Saccharic acid	SA	+	+		Wine vinegar	C	+	+	
Salicylic acid	SA				Wines and spirits	C	+		
Salt water, see sea water		+	+	+	Xylene	TP	0		
Sea water	C	+	+	+	Yeast	D	+		
Silicon acid	D				Yeast	SA	+		
Silicon oil	TP	+	+	+	Zinc carbonate	SA			
Silver acetate	SA				Zinc chloride	SA	+	+	
Silver cyanide	SA				Zinc oxide	SA	+	+	
Silver nitrate	SA	+	+	0	Zinc sulphate	SA	+	+	
Soap	D								
Soda, see sodium carbonate		+	+	0					
Sodium acetate	SA	+	+	+					
Sodium benzoate	SA	+	+						
Sodium bicarbonate	SA	+	+	+					
Sodium biphosphate	SA								
Sodium borate	SA	+	+						
Sodium bromide	SA								
Sodium carbonate	SA	+	+	0					
Sodium chlorate	SA	+	+						
Sodium chloride	SA	+	+	+					
Sodium chlorite	20%	+	0	-					

# Wavin AS+

## Annex II Low noise Soil and Waste specification clauses

### Contents list

- 1000 Application
- 2000 Supplier
- 3000 Materials
- 4000 Performance Objectives
- 5000 Installation
- 6000 Documents to be provided to client

### Wavin AS+, Low noise Soil and Waste system

#### 1000 Application

- ⦿ Soil and waste system

#### 2000 Supplier

- ⦿ Wavin

#### 3000 Materials

- ⦿ Pipe
  - Material: Mineral filled PP, density ~1,9 kg/dm<sup>3</sup>
  - Colour: Grey RAL 7035
  - Stiffness: > 4 kN/m<sup>2</sup>
- ⦿ Fittings
  - Material: Mineral filled PP, density ~1,9 kg/dm<sup>3</sup>
  - Colour: Grey RAL 7035
  - Seal: SBR rubber
- ⦿ Outer diameters (mm) 50; 110; 160; 200

#### 4000 Performances Objectives

- ⦿ Noise barrier properties according to: EN 14366 (Fraunhofer test P-BA 63/2019)
  - 2 l/s WAVIN low noise bracket rubber lined metal bracket
- ⦿ Air borne: 48 dB(A)
- ⦿ Structure borne: 12 dB(A)
- ⦿ Temperature resistance: The pipe system needs to be resistant against continuous temperatures of 90°C and peak temperatures of 95°

#### 5000 Installation

- ⦿ According to Wavin AS+ Installation manual
- ⦿ Bracket fixing instruction: Use full encircling metal brackets with rubber inserts.  
Please use for correct installation the AS+ manual chapter 5 installation

#### 6000 Documents to be provided to the client

Sound level: The contractor needs to demonstrate via an independent programme that the sound level in the rooms shall not exceed the required sound levels. Unless stated otherwise the maximum sound level is: 30 dB(A). Explanation: the sound level is dependent on amongst others the material of the pipe system, the wall thicknesses of the pipe and fittings, the diameter of the system, the flow capacity, the duct material and construction, the type of brackets and mass of the fixation wall and room size. When one of the variables changes, the calculation needs to be repeated with the new input values.

## Discover our broad portfolio at [www.wavin.ie](http://www.wavin.ie)

Hot & Cold Water

Foul Water

Gas & Water Mains

Indoor Climate

Storm Water

Geotextiles

Soil & Waste

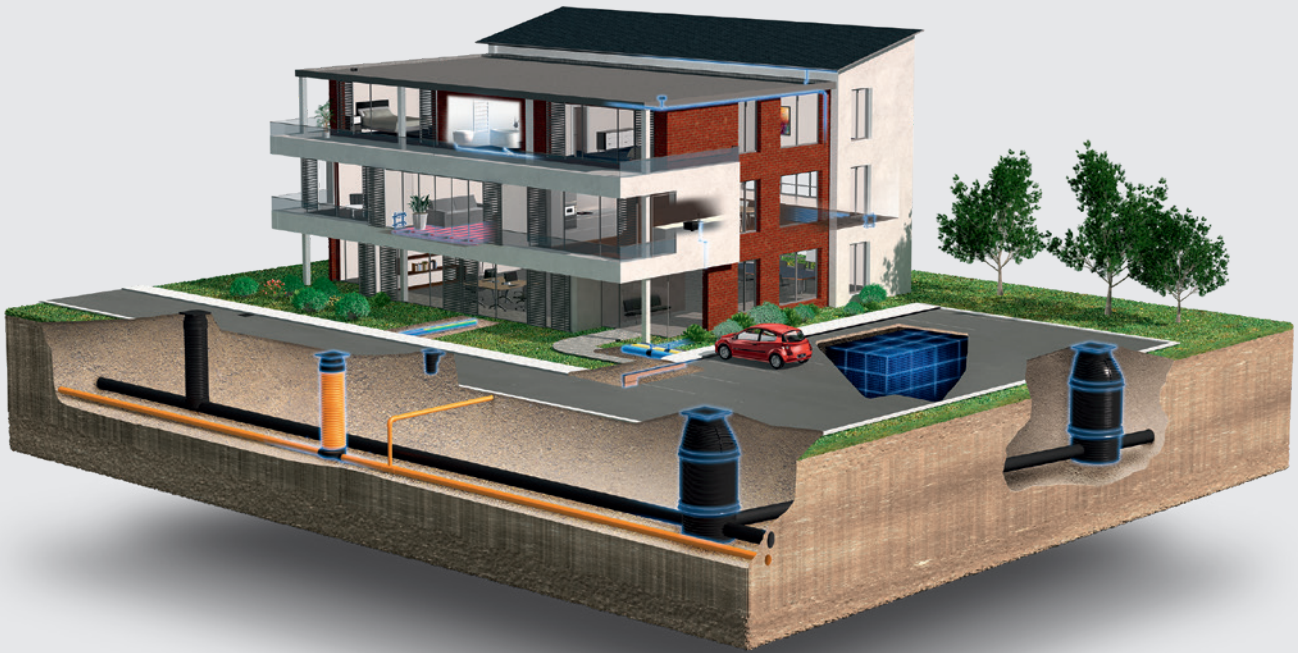

Wavin is part of Orbia, a community of companies working together to tackle some of the world's most complex challenges. We are bound by a common purpose: To Advance Life Around the World.



**Wavin Ireland Ltd** | Balbriggan | Co Dublin | K32 K840  
Tel. 01 8020200 | [www.wavin.ie](http://www.wavin.ie) | [info.ie@wavin.com](mailto:info.ie@wavin.com)

Wavin operates a programme of continuous product development, and therefore reserves the right to modify or amend the specification of their products without notice. All information in this publication is given in good faith, and believed to be correct at the time of going to press. However, no responsibility can be accepted for any errors, omissions or incorrect assumptions.

© 2021 Wavin Wavin reserves the right to make alterations without prior notice. Due to continuous product development, changes in technical specifications may change. Installation must comply with the installation instructions.

For further product information visit: [wavin.ie](http://wavin.ie)