

WAVIN TWINWALL HIGHWAY DRAINAGE SYSTEM

WAVIN TWINWALL POLYPROPYLENE FILTER AND CARRIER PIPES (WITH INTERNAL PIPE DIAMETERS OF 300 mm, 375 mm, 450 mm, 500 mm AND 600 mm), RING SEALS AND COUPLINGS

This Certificate is issued under the Highway Authorities' Product Approval Scheme (HAPAS) by the British Board of Agrément (BBA) in conjunction with the Highways Agency (HA) (acting on behalf of the overseeing organisations of the Department for Transport; the Scottish Executive; the Welsh Assembly Government; the Department for Regional Development, Northern Ireland), the County Surveyors' Society, the Local Government Technical Advisers' Group, and industry bodies. HAPAS Agrément Certificates are normally each subject to a review every five years.

PRODUCT SCOPE AND SUMMARY OF CERTIFICATE

This Certificate relates to Wavin TwinWall Polypropylene Filter and Carrier Pipes (with Internal Pipe Diameters of 300 mm, 375 mm, 450 mm, 500 mm and 600 mm), Ring Seals and Couplings, for use in highway drainage for the collection and disposal of surface and sub-surface water.

AGRÉMENT CERTIFICATION INCLUDES:

- factors relating to compliance with HAPAS requirements
- factors relating to compliance with Regulations where applicable
- independently verified technical specification
- assessment criteria and technical investigations
- design considerations
- installation guidance
- regular surveillance of production
- formal five-yearly review.

KEY FACTORS ASSESSED

Strength — the product has adequate strength to resist loads associated with installation and subsequent use (see section 5).

Performance of the joints — the joints constructed from pipes and couplers with rubber seals remain watertight when subjected to deflection and distortion (see section 6).

Water infiltration — the slot area for the pipes exceeds the minimum relevant requirements (see section 7).

Flow characteristics — the pipes will have normal flow characteristics (see section 8).

Durability — the material from which the pipes and couplers are manufactured will not significantly deteriorate and the anticipated life of the system will be in excess of 50 years (see section 11).



The BBA has awarded this Agrément Certificate to the company named above for the system described herein. This system has been assessed by the BBA as being fit for its intended use provided it is installed, used and maintained as set out in this Certificate.

On behalf of the British Board of Agrément



Brian Chamberlain
Head of Approvals — Engineering



Greg Cooper
Chief Executive

Date of First issue: 19 October 2009

Originally certified on 24 June 2002

The BBA is a UKAS accredited certification body — Number 113. The schedule of the current scope of accreditation for product certification is available in pdf format via the UKAS link on the BBA website at www.bbacerts.co.uk

Readers are advised to check the validity of this Agrément Certificate by either referring to the BBA's website (www.bbacerts.co.uk) or contacting the BBA direct.

HAPAS Requirements

Requirements

The general requirements for drains are contained in the Manual of Contract Documents for Highway Works (MCHW)⁽¹⁾, Volume 1.

(1) The MCHW is operated by the Overseeing Organisations: The Highways Agency (HA), the Scottish Executive, the Welsh Assembly Government and The Department for Regional Development (Northern Ireland).

The general requirements for structural wall pipes and fittings are contained in the MCHW, Volume 1, Clause 518.

Further information and guidance is given in MCHW, Volume 2 and Volume 3 (Drawing Numbers F1 and F2).

Additional site requirements may be included on particular contracts.

Regulations

Construction (Design and Management) Regulations 2007

Construction (Design and Management) Regulations (Northern Ireland) 2007

Information in this Certificate may assist the client, CDM co-ordinator or planning supervisor, designer and contractors to address their obligations under these Regulations.

See section: 1 Description (1.3), 2 Delivery and site handling (2.1), 3 General of the Design Considerations part and 12 General of the Installation part.

General

This Certificate relates to Wavin TwinWall Polypropylene Filter and Carrier Pipes (with Internal Pipe Diameters of 300 mm, 375 mm, 450 mm, 500 mm and 600 mm), Ring Seals and Couplings which are for use in highway drainage for the collection and disposal of surface and sub-surface water.

Technical Specification

1 Description

1.1 Wavin TwinWall, Polypropylene Filter and Carrier Pipes (with Internal Pipe Diameters of 300 mm, 375 mm, 450 mm, 500 mm and 600 mm), Ring Seals and Couplings are manufactured in black polypropylene by a twin extrusion process. Two polypropylene pipes are extruded simultaneously, one inside the other, and heat welded together in one continuous process. Pipes are available plain ended or with integral sockets.

1.2 The products tested and covered by this Certificate are manufactured from material with the specification given in Table 1.

Table 1 Material properties/specification⁽¹⁾

| Property | Test method reference | Specification |
|--|---|---|
| Tensile properties | BS EN ISO 6259-1 : 2001 BS EN ISO 527-1 : 1996 | Sample at 50 mm min ⁻¹ ≥ 20 MPa |
| Oxygen induction time | BS EN 728 : 1997 | ≥ 8 min |
| Melt flow rate | BS EN ISO 1133 : 2005 | ≤ 1.5 g (10 min ⁻¹) 2.16 kg at 230°C |
| Density | ISO 1183-3 : 1999 | ≥ 850 kgm ⁻³ |
| Heat reversion | ISO 12091 : 1995 | 150°C ± 2°C (pass) |
| Effects of heating (injection moulded fittings only) | BS EN ISO 580 : 2005 | N/A |

(1) This table is in the format of Appendix 5/7 of MCHW, Volume 2. It is used to satisfy Clause 518.2 of MCHW, Volume 1.

1.3 The outer wall is corrugated and the inner wall is smooth finished. Details and dimensions are given in Table 2 and Figure 1.

Table 2 Pipe dimensions

| Nominal internal pipe diameter (mm) | External pipe diameter (mm) | t_1 min (mm) | t_2 min (mm) | t_3 min (mm) | Nominal length (m) | Nominal weight (kgm^{-1}) | Integral socket | |
|-------------------------------------|-----------------------------|----------------|----------------|----------------|--------------------|--------------------------------------|-----------------|-------------|
| | | | | | | | Diameter (mm) | Length (mm) |
| 300 | 353.0–356.0 | 1.3 | 2.8 | 1.3 | 6 | 6.0 | — | — |
| 375 | 426.5–430.5 | 1.2 | 2.0 | 1.3 | 6 | 5.8 | 431.8–433.2 | 155–165 |
| 450 | 511.5–516.5 | 1.6 | 4.1 | 2.1 | 6 | 9.5 | 518.2–519.8 | 180–190 |
| 500 | 569.1–574.7 | 1.5 | 4.0 | 2.6 | 6 | 10.4 | 575.3–577.3 | 185–195 |
| 600 | 679.5–686.1 | 1.8 | 5.2 | 2.7 | 6 | 16.6 | 686.0–690.0 | 185–195 |

Figure 1 Wavin Twin Wall pipe

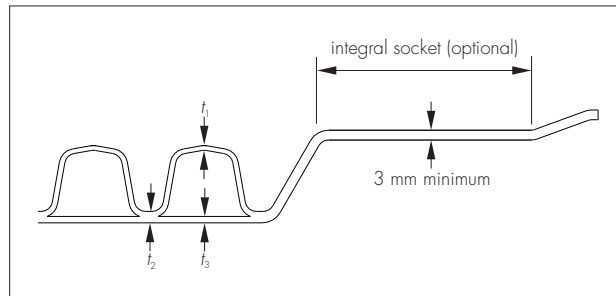

1.4 Black polypropylene pipe couplers are available for each size of pipe (see Table 3 and Figure 2).

Table 3 Pipe coupler dimensions

| Nominal pipe size (mm) | Internal diameter (min) (mm) | Nominal length (mm) | Nominal seal height (mm) |
|------------------------|------------------------------|---------------------|--------------------------|
| 300 | 354.5 | 245.0 | 31.2 |
| 375 | 431.1 | 389.1 | 32.6 |
| 450 | 515.8 | 445.6 | 41.3 |
| 500 | 574.0 | 500.4 | 44.2 |
| 600 | 686.0 | 596.2 | 50.8 |

Figure 2 Pipe coupler

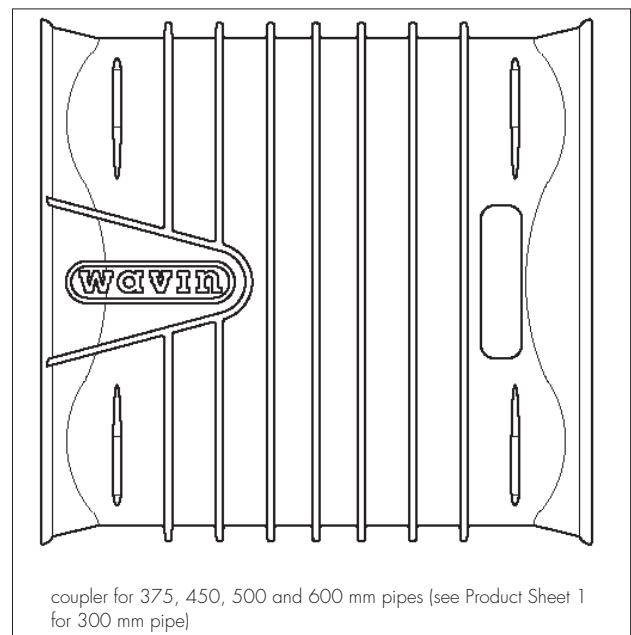

1.5 Seals manufactured to BS EN 681-1 : 1996 (see Figure 3) must be fitted in accordance with the installation instructions to ensure a watertight joint.

Figure 3 Seals

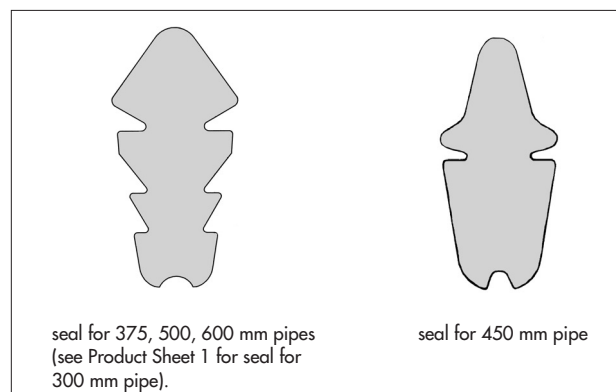

1.6 Pipes can be supplied either slotted or unslotted. Slotted pipe (see Table 4 and Figure 4) is available with the slots in the dwell between corrugations equally spaced around the circumference. Alternatively, the slots are located on one half only of the pipe and thus the number of slots per corrugation root (dwell) and the permeable area is halved.

Table 4 Slotted pipe details

| Nominal internal pipe diameter (mm) | No of slots per dwell | No of dwells per metre | Slot length (mm) | Slot width (mm) | Permeable area (min) (mm^2m^{-1}) |
|-------------------------------------|-----------------------|------------------------|------------------|-----------------|---|
| 300 | 4 | 30 | 20 | 2.5 | 4480 |
| 375 | 4 | 25 | 20 | 3.5 | 6266 |
| 450 | 4 | 20 | 25 | 3.5 | 6327 |
| 500 | 4 | 17 | 30 | 3.5 | 6687 |
| 600 | 4 | 15 | 35 | 3.5 | 6747 |

Figure 4 Details of slots

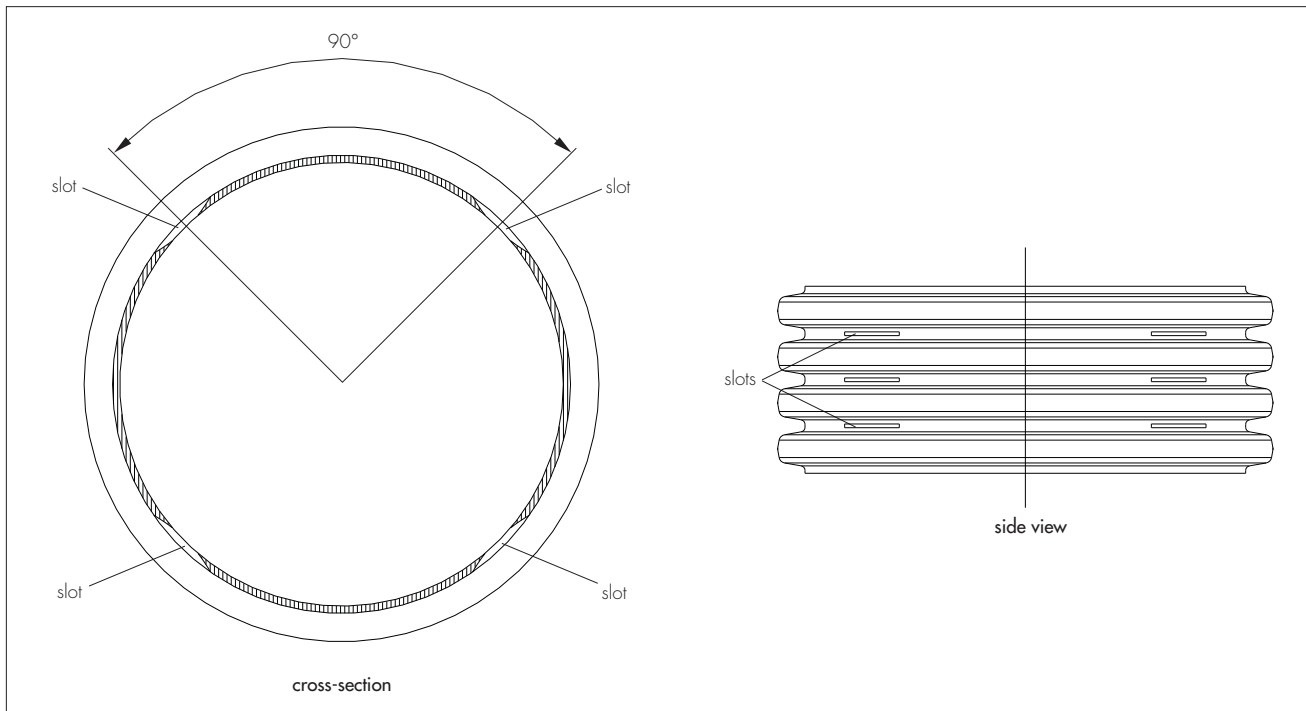

1.7 Continuous quality control is exercised during manufacture. Checks include:

Pipes

- dimensional accuracy
- visual
- marking
- impact resistance
- weight

Couplers

- dimensional accuracy
- marking.

1.8 The BBA Certificate number is printed on each pipe length or printed on a label for each pack of couplers in the size range of from 375 mm to 600 mm.

2 Delivery and site handling

2.1 Handling, storage and transportation should be in accordance with MCHW and the manufacturer's instructions.

2.2 When long-term storage is envisaged, Wavin TwinWall slotted and unslotted filter and carrier pipes and couplings must be protected from direct sunlight. If protection cannot be provided, consideration must be given to the effects of daily exposure to direct sunlight:

- up to 3 months — negligible UV degradation but possible extreme surface temperatures of up to 80°C may cause some localised distortion
- 3 to 12 months — may have significant effect on the impact resistance and physical properties
- over 12 months — damage will occur unless protection provided.

2.3 Pipes should be suitably supported at a minimum of two places when being lifted. Protected slings should preferably be used, but if metal hooks or chains are used then padding should be placed between them and the pipes.

2.4 Pipes should be stored on a flat surface, free from sharp projections, stones or other protuberances. They are generally delivered in pre-packed bundles and should be retained in the packing until installation. Care should be taken to avoid dropping the pipes on their ends, particularly during cold weather conditions.

Assessment and Technical Investigations

The following is a summary of the assessment and technical investigations carried out on Wavin TwinWall Polypropylene Filter and Carrier Pipes (with Internal Pipe Diameters of 300 mm, 375 mm, 450 mm, 500 mm and 600 mm), Ring Seals and Couplings.

Design Considerations

3 General

Wavin TwinWall Polypropylene Filter and Carrier Pipes (with Internal Pipe Diameters of 300 mm, 375 mm, 450 mm, 500 mm and 600 mm), Ring Seals and Couplings, comply with the requirements of the MCHW, Volume 1, Clause 518.5 for pipe, Clause 518.6 for couplers and Clause 518.7 for the system. When installed in accordance with the recommendations given in this Certificate, they are suitable for use in highways for the collection and disposal of surface and sub-surface water.

4 Design considerations

4.1 The product is designed to be installed by a competent contractor, experienced with this type of product.

4.2 The pipes are installed easily using traditional drain-laying methods in accordance with the HA requirements and Clauses 503, 505 and 518 of MCHW, Volume 1. The lengths in which the pipes are available and their lightness in weight are a significant advantage in handling and installation. Jointing of the pipes is achieved easily.

5 Strength

4.1 The product has adequate strength to resist loads associated with installation and with subsequent use. The ring stiffness of the pipe exceeds the minimum requirement of 6 kNm^{-2} and has a creep ratio of less than 4.

4.2 For the determination of safe bedding depth to Highways Agency Standards HA 40/01, pipe can be considered to have a stiffness greater than 6 kNm^{-2} .

4.3 The pipes have adequate resistance to impact loads to which they may be subjected to during installation and in service. Care should be taken during site handling and installation to avoid dropping the pipes on their ends, particularly during cold weather conditions.

6 Performance of joints

6.1 Joints on filter pipes made from pipe and couplers without the rubber seals are not partially watertight as defined in the MCHW, Volume 1, Clause 504.3.

6.2 Correctly made, the joints constructed from pipe and couplers with rubber seals remain watertight when subjected to deflection and distortion, and comply with the MCHW, Volume 1, Clauses 504.3 and 518.7 (see section 14).

7 Water infiltration

The slot area for the pipes exceeds the minimum requirement given in MCHW, Volume 1, Clause 518.3, of 1000 mm^2 per metre length.

8 Flow characteristics

8.1 The pipes will have normal flow characteristics associated with PVC-U pipes.

8.2 Full-bore velocity values are available from H R Wallingford and D I H Barr *Table for the Hydraulic Design of Pipes, Sewers and Channels*, Volume 2, 8th Edition. The values are based on the Colebrook-White equation. An appropriate value of roughness coefficient should be selected when designing the drainage system. For new pipes, a value of 0.006 mm is applicable, but for designs, a value of 0.6 mm is generally used.

9 Resistance of chemicals

The pipes will be unaffected by those types and quantities of chemicals likely to be found in surface water.

10 Maintenance

10.1 The slots are designed to restrict the ingress of silt into the drains.

10.2 Access to the system for cleaning should be provided by conventional methods.

10.3 The system can be rodded easily using flexible drain rods. In common with other standard plastic drainage systems, toothed root cutters and rods with metal ferrules, as used with some mechanical clearing systems, could damage the pipes and couplers and should not be used.

10.4 Tests indicate that the pipes have adequate resistance to water cleansing using pressure jetting equipment (see section 14.1). It is recommended that low-pressure, high-volume systems are utilised in accordance with MCHW, Volume 1, Clause 520.

11 Durability

In the opinion of the BBA, when used in the context of this Certificate, the material from which the pipes and couplers are manufactured will not significantly deteriorate and the anticipated life of the system will be in excess of 50 years.

Installation

12 General

Wavin TwinWall Polypropylene Filter and Carrier Pipes (with Internal Pipe Diameters of 300 mm, 375 mm, 450 mm, 500 mm and 600 mm), Ring Seals and Couplings must be installed in accordance with the HA requirements and Clauses 503, 505, 518.7 and 518.8 of MCHW, Volume 1.

13 Procedures

13.1 For typical laying, trench and backfilling specification details reference should be made to Figure 5 and the MCHW, Volume 3, Drawing No F1 (Types T and S) and F2 (Types G, H and I).

Figure 5 Installation details

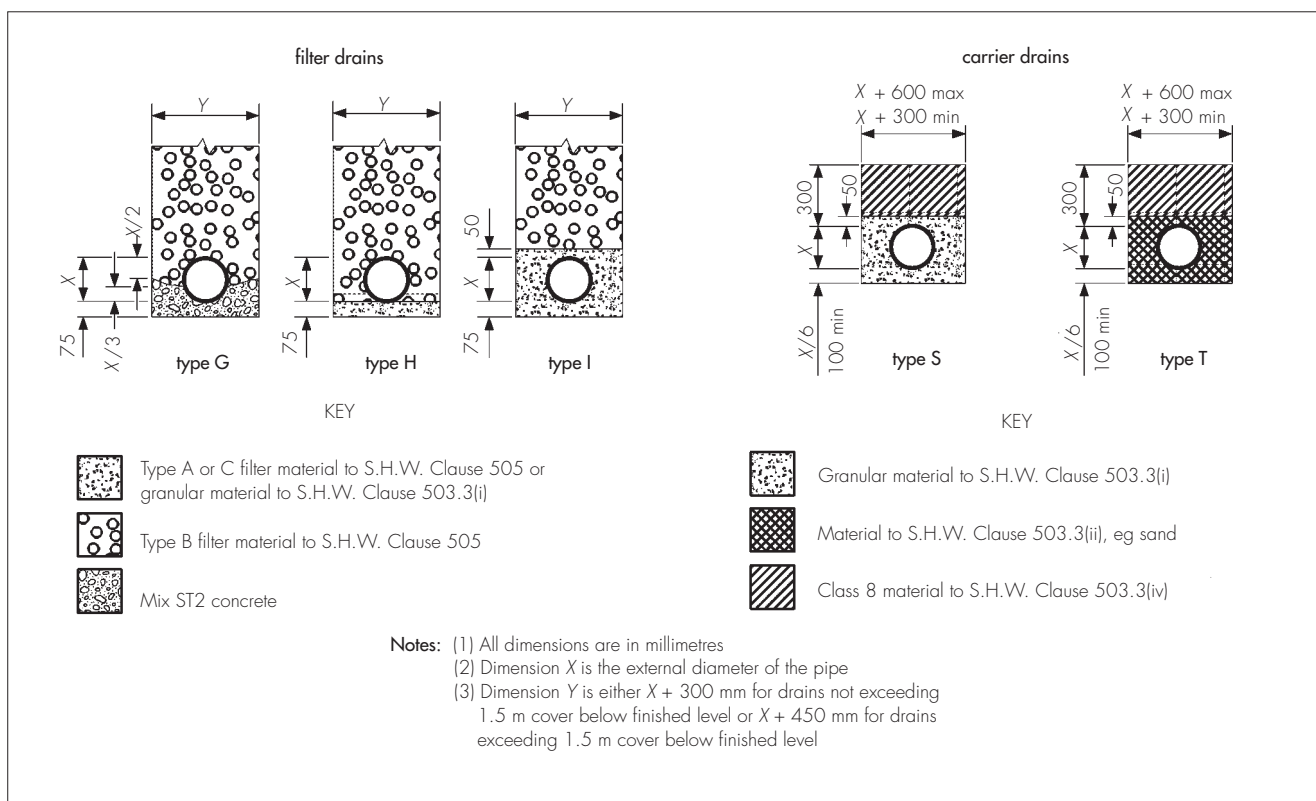

13.2 Pipes are cut easily using conventional hand tools, and should be cut square between the corrugations.

13.3 For a watertight joint, the pipe ends and coupler should be cleaned and a rubber seal fitted externally between the first and second corrugation in the pipe. The inside of the coupler should be lubricated and the pipe pushed fully home to the central register either by hand, or using a lever if necessary.

13.4 The slotted and unslotted pipes and couplings must be protected against damage from site construction traffic.

13.5 Care should be taken during backfill to maintain the line and level of the pipeline. If necessary, the pipe should be restrained to prevent uplift.

14 Tests

14.1 Tests were carried out on the pipe to determine compliance with MCHW, Volume 1, Clause 518.5 on:

- determination of ring stiffness to BS EN ISO 9969 : 1995
- creep ratio to BS EN ISO 9967 : 1995
- resistance to longitudinal bending to MCHW, Volume 1, Clause 518.11
- impact strength at 0°C and 23°C to BS EN 1411 : 1996 with a d25 striker of 1.0 kg mass
- rodding resistance to MCHW, Volume 1, Clause 518.12
- water jetting WRc method.

14.2 Tests were carried out on joined pipe to establish compliance with MCHW, Volume 1, Clause 518.7 on:

- leaktightness of joints to BS EN 1277 : 1996 when subjected to diameter distortion and angular deflection from 0.5 bar to -0.3 bar
- insertion force (ease of jointing)
- resistance to rodding.

14.3 Tests were carried out to establish the dimensional accuracy of the pipe, coupler and ring seal to ISO 11922-1 : 1997.

15 Investigations

15.1 An examination was made of data in relation to the affect of the production tolerances on the performance of the products.

15.2 An evaluation of existing data was made to assess material properties, chemical resistance and durability.

15.3 Calculations were carried out to determine the slot area.

15.4 The manufacturing process was examined, including the methods adopted for quality control, and details were obtained of the quality and composition of the materials used.

Bibliography

BS EN 681-1 : 1996 *Elastomeric seals — Material requirements for pipe joint seals used in water and drainage applications — Vulcanized rubber*

BS EN 728 : 1997 *Plastics piping and ducting systems — Polyolefin pipes and fittings — Determination of oxidation induction time*

BS EN 1277 : 1996 *Methods of testing plastics — Thermoplastics pipes, fittings and valves — Plastics piping systems — Thermoplastics piping systems for buried non-pressure applications — Test methods for leaktightness of elastomeric sealing ring type joints*

BS EN 1411 : 1996 *Plastics piping and ducting systems — Thermoplastics pipes — Determination of resistance to external blows by the staircase method*

BS EN ISO 527-1 : 1996 *Methods of testing plastics — Mechanical properties — Determination of tensile properties — General principles*

BS EN ISO 580 : 2005 *Plastics piping and ducting systems — Injection-moulded thermoplastics fittings — Methods for visually assessing the effects of heating*

BS EN ISO 6259-1 : 2001 *Thermoplastics pipes — Determination of tensile properties — General test method*

BS EN ISO 9967 : 1995 *Thermoplastics pipes — Determination of creep ratio*

BS EN ISO 9969 : 1995 *Thermoplastics pipes — Determination of ring stiffness*

BS EN ISO 1133 : 2005 *Plastics — Determination of the melt mass-flow rate (MFR) and the melt volume-flow rate (MVR) of thermoplastics*

ISO 1183-3 : 1999 *Plastics — Methods for determining the density of non-cellular plastics — Gas pycnometer method*

ISO 11922-1 : 1997 *Thermoplastics pipes for the conveyance of fluids — Dimensions and tolerances — Metric series*

ISO 12091 : 1995 *Structural wall thermoplastics pipes — Oven test*

HA 40/01 *Design Manual for Roads and Bridges : Volume 4, Geotechnics and Drainage, Section 2, Drainage : Part 5, Determination of Pipe and Bedding Combinations for Drainage Works*

Manual of Contract Documents for Highway Works, Volume 1 *Specification for Highway Works*, August 1998 (as amended)

Conditions of Certification

16 Conditions

16.1 This Certificate:

- relates only to the product/system that is named and described on the front page
- is granted only to the company, firm or person named on the front page — no other company, firm or person may hold or claim any entitlement to this Certificate
- is valid only within the UK
- has to be read, considered and used as a whole document — it may be misleading and will be incomplete to be selective
- is copyright of the BBA
- is subject to English law.

16.2 Publications and documents referred to in this Certificate are those that the BBA deems to be relevant at the date of issue or re-issue of this Certificate and include any: Act of Parliament; Statutory Instrument; Directive; Regulation; British, European or International Standard; Code of Practice; manufacturers' instructions; or any other publication or document similar or related to the aforementioned.

16.3 This Certificate will remain valid for an unlimited period provided that the product/system and the manufacture and/or fabrication including all related and relevant processes thereof:

- are maintained at or above the levels which have been assessed and found to be satisfactory by the BBA
- continue to be checked as and when deemed appropriate by the BBA under arrangements that it will determine
- are reviewed by the BBA as and when it considers appropriate
- remain in accordance with the requirements of Highways Authorities' Product Approval Scheme.

16.4 In granting this Certificate, the BBA is not responsible for:

- the presence or absence of any patent, intellectual property or similar rights subsisting in the product/system or any other product/system
- the right of the Certificate holder to manufacture, supply, install, maintain or market the product/system
- individual installations of the product/system, including the nature, design, methods and workmanship of or related to the installation
- the actual works in which the product/system is installed, used and maintained, including the nature, design, methods and workmanship of such works.

16.5 Any information relating to the manufacture, supply, installation, use and maintenance of this product/system which is contained or referred to in this Certificate is the minimum required to be met when the product/system is manufactured, supplied, installed, used and maintained. It does not purport in any way to restate the requirements of the Health & Safety at Work etc Act 1974, or of any other statutory, common law or other duty which may exist at the date of this Certificate; nor is conformity with such information to be taken as satisfying the requirements of the 1974 Act or of any statutory, common law or other duty of care. In granting this Certificate, the BBA does not accept responsibility to any person or body for any loss or damage, including personal injury, arising as a direct or indirect result of the manufacture, supply, installation, use and maintenance of this product/system.